

# A SHADE OF RED. RED SLIP WARE AT ZINCIRLI AND ITS CONNECTIONS WITH NORTHERN SYRIA AND SOUTHERN ANATOLIA IN THE IRON AGE

SEBASTIANO SOLDI\*

*Abstract:* This paper presents new ceramic data from the excavations conducted by the Chicago-Tübingen Expedition at Zincirli, the capital of the Iron Age kingdom of Sam'al, in south-eastern Turkey. Excavations in the lower town and on the citadel mound revealed a small but relevant collection of Red Slip Ware dated to the local Iron Age II and III. The local pottery inventory shows clear connections with the material culture of northern inland Syria, especially with the sites of the Amuq, the Idlib and Aleppo plains and the Euphrates area. The sample of Zincirli shows that Red Slip is abundant and associated to Cypriot-style painted wares in the early Iron Age II (9th – middle of 8th century BCE) and tends to decrease, to almost disappear, in the Iron Age III (mid 8th – 7th century BCE). In this later period the pottery production seems to be gradually affected by the Assyrian presence in the region, as Sam'al is included into the realm of the Neo-Assyrian empire, with the adoption of some new pottery types and glazed decorations, and the abandonment of the local red slip treatment.

*Keywords:* Northern Levant; Zincirli; Iron Age; Red Slip; Pottery.

## 1. INTRODUCTION

A series of archaeological activities in the Northern Levant in the recent years of the new millennium focused on resuming excavations at sites which were extensively dug in the first half of the 20th century.<sup>1</sup> This new wave of archaeological operations concentrates especially along the Turkish side of the border dividing the modern Republics of Turkey and Syria, and is currently providing a new fresh set of data on the historical settlements belonging to the so-called Syro-Hittite kingdoms of the Iron Age. This new approach to long-time excavated sites offers the chance to reassess and reevaluate the local material culture by contextualizing it in its proper archaeological and stratigraphic setting and by comparing it on a regional level. Questions of urbanism, settlement's development, material culture (ceramics and small finds), craftsmanship and iconography as well as environmental and paleobotanical studies, can be addressed with a fresh look that new stratigraphic excavations can provide.

The main archaeological sites touched by these activities and relevant to the purpose of the present paper are Tell Tayinat/Kunulua, Zincirli Höyük/Sam'al and Karkemish in Turkey, three of the most representative capital-cities of the Luwian-Aramaeans of the early first millennium BCE.<sup>2</sup> Archaeolog-

---

\* Museo Archeologico Nazionale, Firenze / Eberhard Karls Universität Tübingen / Università degli Studi di Firenze; sebastiano.soldi@beniculturali.it.

1 This study has been possible thanks to the grant of the Deutsche Forschungsgemeinschaft (DFG) "Amorites and Aramaeans at Sam'al: Comparing Middle Bronze and Iron Age Urbanism and Economy at Zincirli, Turkey" (2020-2021) coordinated by Dr. Virginia R. Herrmann (Eberhard Karls Universität Tübingen, IANES Department), and to the grant that I have been awarded by the Mediterranean Archaeological Trust (2019). I would like to thank David J. Schloen and Virginia R. Herrmann, co-directors of the Chicago-Tübingen Expedition to Zincirli, for supporting the study of the pottery from Zincirli and for the fruitful discussions on the materials and the settlement's phasing, the ceramic assistants Giovanna Tiziana Genna and Livia Tirabassi, and the draughtsman Cem Küncü. I also would like to thank the anonymous reviewers, whose comments have improved the topics' discussion in the article. Needless to say, any mistake or incorrect interpretation is only the author's fault.

2 We mention here only few selected Iron Age sites that are providing new publications useful to the present subject, though we need to stress that many more projects in the region are increasing the knowledge of this vast area in the Bronze and Iron Ages

ical activities on the Syrian side of the border have been prevented by the outbreak of the Syrian crisis since 2011, forcing a stop of major operations conducted at long-time excavations (such as Tell Afis/Hazrek and Tell Mardikh/Ebla) as well as the new projects resuming old excavations (such as Tell Mishrifeh/Qatna or Tell Fekheriyeh/Washshukanni and Tell Halaf/Guzana).

Among the archaeological issues that can be explored by following the development of latest results in the region, we need to stress on the studies regarding the ceramic repertoire and its contexts, functions and chronologies. It is a sensible issue because modern excavations provide ceramics within a controlled stratigraphic location in order to build up a detailed chronological sequence.

Thanks to this opportunity we can now increase our knowledge and evaluate the impact and consistency of different classes of materials within the Luwian-Aramean historical region of Northern Syria and southern Anatolia, identifying patterns and changes that evolve from the collapse of the Late Bronze Age system to the formation of local independent kingdoms in the Iron Age I and II until their inclusion and subjugation in the Neo-Assyrian empire in the Iron Age III. Different regional points of view can be adopted and different classes of materials can be the subject of such reviews.

We will focus here on the impact of Red Slip ware in the area of Zincirli, which is the narrow Kara Su Valley, and its implications and connections with major contact areas: the Euphrates to the east, the Amuq and the north Syrian plains to the south, and Cilicia to the west.

The point of view of Zincirli, ancient Sam'al, is a peculiar one because of its northern location within the area of Aramean kingdoms, on the crossroads between Syria and Anatolia, and seat of a flourishing settlement with monumental buildings, carved orthostats and inscriptions in Luwian, Aramean, Phoenician and Assyrian dated between the 9th and the 7th century BCE. We can therefore examine the local ceramic assemblage and the presence of Red Slip in its context during the Iron Age II and III, and observe this phenomenon in this northernmost valley on the eastern side of the Amanus mountains.

## 2. THE STATE OF THE ART ON RED SLIP POTTERY IN THE NORTHERN LEVANT

Red Slip pottery is part of the larger ceramic assemblage of pottery production of the Levant during the Iron Age. Chronology, distribution and function of the ceramics production have been already debated and well established by several scholars, both in the southern and in the Northern Levant, as well as in Phoenicia and Cyprus.<sup>3</sup> Yet a deeper understanding of Red Slip at a regional and local level is still needed, especially in the Northern Levant, where this class of materials is well attested but not always in a good archaeological context or present in relevant quantity.<sup>4</sup> We can nevertheless assert that Red Slip is one of those common features characterizing the pottery production throughout inland Syria, reflecting very clearly the standardized mass-produced ceramic inventory of the region. The issue of how much the employment of red clay engobe overlaps with the general assemblage of simple ware shapes is a focal point, also in order to understand the function of the use of the slip, which was applied only to certain morphologies and not to others.

Among the main issues which still shall be discussed on Red Slip in the northern Levant, and that this article will cope with, are: the chronology with special regard to its beginning and its disappearance from the

---

(from Tarsus/Gözlükule, Sirkeli Höyük, Misis Höyük, and Kinet Höyük in Cilicia, to Tell Atchana/Alalakh in the Amuq and Tilmen Höyük in the Kara Su Valley).

<sup>3</sup> For the Northern Levant, see especially Lehmann 1996 and 1998; Mazzoni 1992, 2000 and 2014; recently the chronological framework has been resumed in Osborne 2021, pp. 26-29 and new comprehensive evaluation of data for the Amuq is provided by Pucci 2019.

<sup>4</sup> See the recent discussion by Pucci – Soldi 2019, focusing on Chatal Höyük, Tell Afis and Zincirli. Pioneering studies on this issue have been conducted by Marc Lebeau on the limited but still relevant sample of Iron Age ceramics from Tell Abu Danné (Lebeau 1983) and the study specifically devoted by Frank Braemer to the Red Slip of the coastal Syrian site of Ras el Bassit (Braemer 1986).

archaeological record; diffusion in the area enclosed by the Euphrates on the east and the Amanus and the Orontes on the west; technological features, especially the employment of burnishing associated to engobe; possible origin as a production in the local inventory or influences from abroad (e.g. Phoenician / southern Levant or Anatolian).

We will approach the new finds from Zincirli's last archaeological seasons and we will compare them with other documentation in order to shed light on the above mentioned issues.

Regionalization is probably the compelling new setting emerging from latest studies. We can assume an overall presence of a common ceramic horizon characterizing the region in the Iron Age II, but local variations from site to site or within a network of micro-regional enclaves seem to be the most correct way to interpret this phenomenon on a larger scale.<sup>5</sup>

### 3. ZINCIRLI'S LOCATION AND ITS PRINCIPAL ARCHAEOLOGICAL FEATURES

Zincirli Höyük is located in southeastern Turkey, in the province of Gaziantep, 10 km north of modern İslahiye and about 30 km north of the Syrian border (FIG. 1). It lies on the western side of the Kara Su Valley, a narrow fertile valley closed on the eastern side by the Kurt Dağı and on the western side by the high peaks of the Amanus Mountains (Nur Dağları), known from the antiquity for its timber woods and rich in fresh spring water from the mountains which flows into the Kara Su river plain. The valley runs from northeast to southwest, connecting the Kahramanmaraş Plain and Taurus Mountains to the north and the Amuq Plain (Hatay) and Orontes River to the south, thus forming a natural corridor between western Syria and the Anatolian plateau. The northern edge gives access to Kahramanmaraş (Marash), the ancient capital of the kingdom of Gurgum, and hence, through the Göksum pass, to the Anatolian plateau and the Taurus Mountains.

The southern extension, opening onto the Plain of Antioch, is where major archaeological sites are located, such as Bronze Age Tell Atchana/Alalakh and Tell Tayinat/Kunulua, the capital of the Iron Age kingdom of Unqi/Patina. The area of Antioch was one of points of access from Anatolia to the great plains of Syria and to the region of Aleppo, connecting the Syro-Mesopotamian world with the eastern Mediterranean shores. The location of Zincirli was strategic also because of the east-west connections, since it lies on the road linking the area of Karkemish, on the Euphrates on the present day Syro-Turkish border, and Cilicia and the eastern Mediterranean coast, which can be reached through the Bahçe Geçidi, known in the Classical period as the Armanian Gates. Therefore, the setting of Zincirli is in a distinctive location well connected to strategic areas, and its archaeological records show a long sequence of occupation, spanning from the 3rd to the 1st millennium BCE.<sup>6</sup>

The site is composed by an upper mound of ca. 5 ha rising 15 m above a circular lower town of 39 ha as the maximal expansion of the settlement during its Iron Age II-III phase. The citadel lies at the center of the town, which is enclosed by a double city wall with three main city gates. Zincirli is well known for being the capital city of the ancient Aramaean kingdom of Sam'al, also known in ancient texts as Y'DY, flourishing between 900 and 700 BCE, though archaeological evidence clearly proves that it was inhabited also in the Early and Middle Bronze Age (end of 3rd millennium BCE until mid of 2nd millennium BCE).<sup>7</sup>

Zincirli was first excavated by a pioneering German Orient-Comité expedition between 1888 and 1902 through five archaeological campaigns.<sup>8</sup> The results of this expedition settled the ground for the first historical understanding of this pre-Classical settlement and for this area of southern Turkey and north-west-

5 See recently Pucci – Soldi 2019.

6 Wartke 2005, pp. 17-19; Schloen 2014, pp. 27-30.

7 Latest results on the Middle Bronze Age settlement in Herrmann – Schloen 2021 and Morgan – Soldi 2021.

8 Wartke 2005.

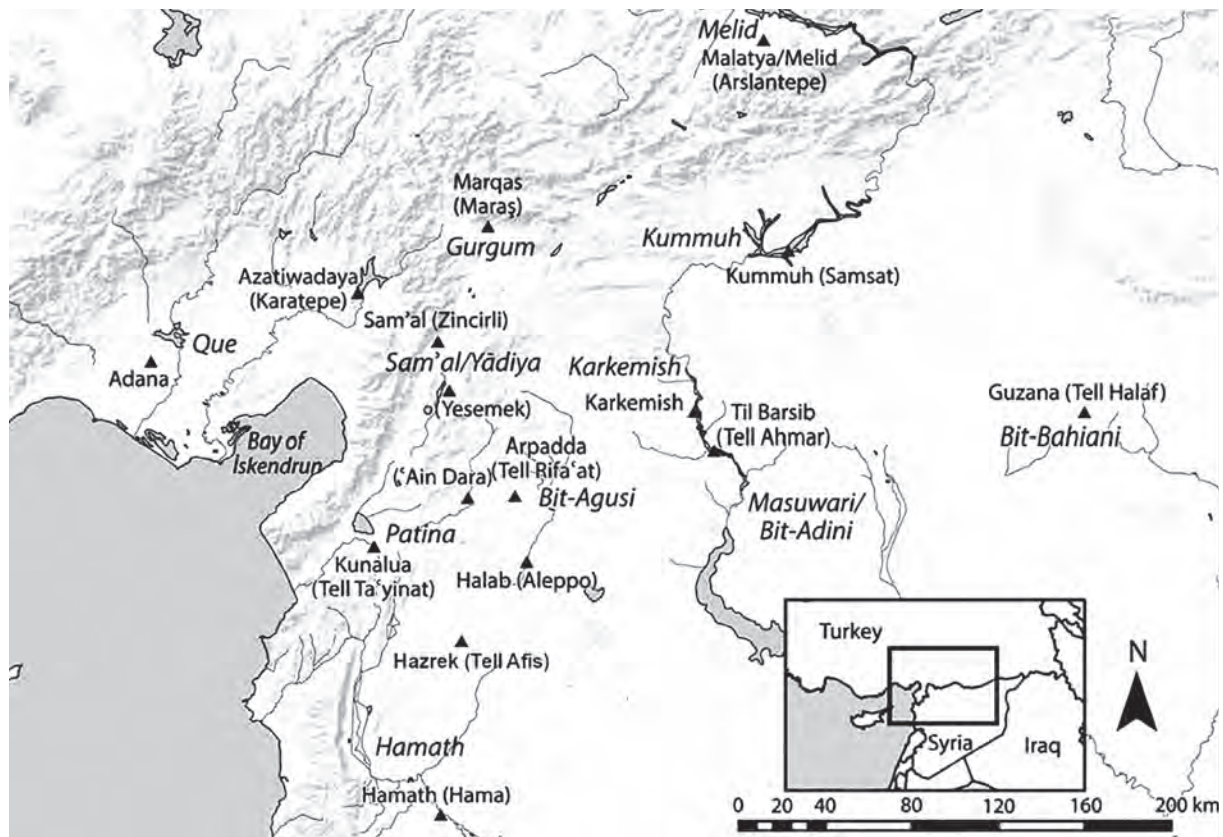

FIG. 1. Zincirli/Sam'al and the Northern Levant in the Iron Age II (after Herrmann 2017a, fig. 1 and modified by the author).

ern Syria, providing rich documentation in stone sculptures, inscriptions and small finds, which are nowadays displayed and stored in Istanbul's *Eski Şark Eserleri Müzesi* and Berlin's *Vorderasiatisches Museum*. Since 2006 a new expedition of the Oriental Institute of the University of Chicago undertook excavations under the direction of David Schloen, and in 2014 the University of Tübingen joined in the project, establishing the current Chicago-Tübingen Expedition.

Several new excavation areas both in the upper mound and in the lower town have increased the exposed surface and provided a fresh set of data useful to get a deeper insight into the main periods of occupation of the site and to understand the local sequence of materials in their stratigraphic and architectural contexts.

The exploration of the settlement has been carried out by opening different excavation areas on the citadel, in the lower town and in the outer town in the proximity of the city walls, for a total of ten excavation areas (FIG. 2). New excavation trenches on the upper mound are in Area 2 on the eastern citadel, which has revealed an overlapping of the Iron Age buildings (already excavated by the German expedition) with the Middle Bronze II settlement,<sup>9</sup> and in Area 3, on the southern slope of the mound, where the extended step trench yields the Iron Age II and III occupation sequence, lying on top of the Early Bronze Age settlement.<sup>10</sup> The lower town is the portion of the site which has been more investigated in the first place by the Chicago-Tübingen expedition to obtain information on the urbanization in the period of largest expansion

9 An interim archaeological report of the MBA phase in Area 2 in Morgan – Soldi 2021.

10 Schloen – Fink 2009, pp. 211-212; Herrmann – Schloen 2018, pp. 524-525.



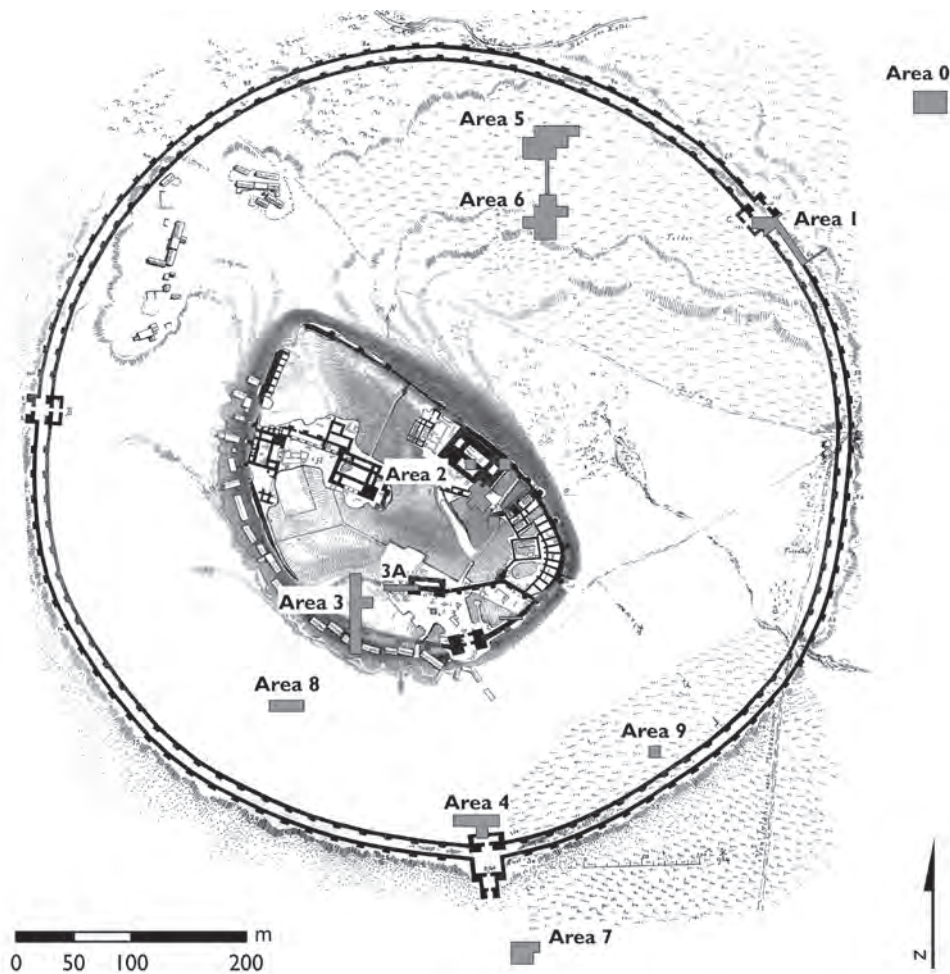

FIG. 2. Plan of Zincirli combining the results of the Orient-Comité expedition and the Chicago-Tübingen excavation areas (courtesy the Chicago-Tübingen Expedition to Zincirli; elaborated by J.T. Herrmann).

of Sam'al, between the 9th and 7th centuries BCE: two large excavation areas have been explored in the northern part of the lower town (Areas 5 and 6),<sup>11</sup> and two in the southern part (Areas 4 and 8).<sup>12</sup> More trenches have investigated the northeast city wall and gate (Area 1)<sup>13</sup> and *extra-moenia* buildings (Areas 0 and 7)<sup>14</sup> providing supplementary information on the Iron Age settlement.

The understanding of the Iron Age sequence and the settling up of the typological framework for the local ceramics productions have been among the efforts carried out in these latest years of work, matching the data coming from the lower town excavation areas with those from the citadel's ones, and combining these results with previous documentation offered by the publications of the German Orient-Comité expedition and other relevant excavations in the region.

11 Schloen – Fink 2009, pp. 214-215; Herrmann 2017b, pp. 289-301.

12 Schloen – Fink 2009, pp. 212-214; Herrmann – Schloen 2018, pp. 525-527.

13 Schloen – Fink 2009, pp. 209-210.

14 Schloen – Fink 2009, p. 216.

CENTURY	YEARS BCE	RELATIVE CHRON. (NW SYRIA)	ZINCIRLI CITADEL (Area 3)	ZINCIRLI N. LOW. TOWN (Area 5)	AMUQ PHASES (Chatal H.)	TELL TAYINAT (Bldg Per - Field I, II)	TELL AFIS (Area E)
10th c. BCE	950	IA IB			N mid	Field I Phase 4	III
	900	IA IC	Phase 11		N late	Phase 3	II b
9th c. BCE	850	IA IC/IA IIA	Phase 10 Phase 9 Phase 8			O beg	BP I Bldg. XIV
	800	IA IIA		Phase 2e	BP I F. I 2d-2c		I cb
8th c. BCE	750	IA IIB	Phase 7 Phase 6	Phase 2d	O mid		BP II Bldgs. II, XVI
	700	IA III	Phase 5 Phase 4	Phase 2c		BP II Bldg. XVI	
7th c. BCE	650			Phase 2b		BP III Bldg. XVI	
	600	Phase 2a	BP IV				

FIG. 3. Tentative chronological phasing of Zincirli's Area 3 (citadel mound) and 5 (north lower town) based on  $^{14}\text{C}$  data, stratigraphy and pottery (V.R Herrmann and S. Soldi), compared to general north-west Syria chronological reference (Lehmann 2008, Mazzoni 2014) and relevant sequences at Chatal Höyük (Pucci 2019), Tell Tayinat (Osborne *et al.* 2019) and Tell Afis (Venturi 2020).

#### 4. OVERVIEW OF THE CERAMICS INVENTORY OF IRON AGE II AND III AT ZINCIRLI

The local pottery assemblage of Zincirli belongs to the regional horizon of Northern Syria in the Iron Age, as it is characterized by a vast majority of simple ware open shapes in light-red or “orange” fabric, after the overall homogeneous colour of the pottery sherds. This ceramics assemblage is common to the whole region of north-western Syria, which is the area roughly included between the Euphrates and the Mediterranean coast, bordering on the northern edge with the Anatolian plateau and south with the Lebanon mountains and the Syrian desert. Zincirli fits generally with this ceramic tradition in the Iron Age II and III, presenting some peculiar regional traits (shared with other sites in the İslahiye Valley and in the region of Gaziantep) and showing an increasing influence of Assyrian forms towards the end of the period.

A clear identification trait for the pottery of western Syria is the simple ware fabric: the light-red fabric, sometimes called “orange ware”, characterizes most of local productions of simple ware, employed for processing (except for cooking), serving and consuming food; a limited range of local variations is due to the different sources of raw materials, with technological aspect (firing and surface treatments) tending to be rather homogenous within the whole region. The association of such fabric to distinctive surface treatments (polishing and burnishing, presence of reddish clay wash or slip) and to a specific set of morphologies (plates, bowls, jugs and jars), constitutes the typical mark to the western Syrian assemblage of Iron Age II and III, historically attested between the mature period of the so-called Syro-Hittite kingdoms and the emergence of the Neo-Assyrian power over the region.<sup>15</sup>

The ceramics inventory elaborated through the new Chicago-Tübingen excavations is consistent in the upper and lower town, and associated to specific findings which allow a firm reference to date the assemblage, supported as well by a program of  $^{14}\text{C}$  analysis (FIG. 3). The main historical resource is the well-known funerary stele of Katumuwa, an official of king Panamuwa II, found within his mortuary chapel, belonging to Phase 2c of Building A/II in northern lower town's Area 5, which provides a date for the stele between

<sup>15</sup> Lehmann 1998; Mazzoni 2000.

No.	Field N.	Class	Shape	Fabric Colour	Surface Treatment	Decoration
a	C11-394	SW	Plate	2.5YR5/8 red		
b	C10-325	SW	Plate	7.5YR5/4 brown		
c	R07-580	SW	Bowl	2.5YR6/8 light red		
d	C09-382	SW	Bowl	2.5YR6/8 light red		
e	C08-89	SW	Krater	2.5YR5/6 red		
f	C11-116	SW	Krater	2.5YR6/8 light red		

743/740 and 733/732 BCE.<sup>16</sup> The similarity of the inventory and the repetition of some peculiar features in other areas is helpful in establishing synchronisms, especially with Area 8 Phase 4b in the southern lower town, where a well preserved domestic and kitchen assemblage was excavated.<sup>17</sup>

The inventory of simple ware, kitchen and storage ware is very homogenous throughout the subphases of Areas 5 and 6 in the northern portion of the lower town, as well as in Area 8 Phase 4 in the southern lower town, showing a strong continuity of the whole pottery horizon throughout the late Iron Age II and the Iron Age III period, e.g. from the mid 8th century to the 7th century BCE.<sup>18</sup>

Main shapes of local simple ware are open forms representing the vast majority of the assemblage, mostly plates and bowls with a few variants, and a minor number of kraters, deep and large bowls to mix and pour liquids.

Plates (FIG. 4.a-b) have simple rounded rim and flat disc or slightly concave base, less frequently ring base. It is a very common shape all over North Syria since Iron Age I, originating from Late Bronze Age prototypes;<sup>19</sup> the association of such shape with the light red fabric is a clear trademark of the Iron Age II-III horizon. As we will see below, large conical platters are the main shape of Red Slip Burnished Ware attested

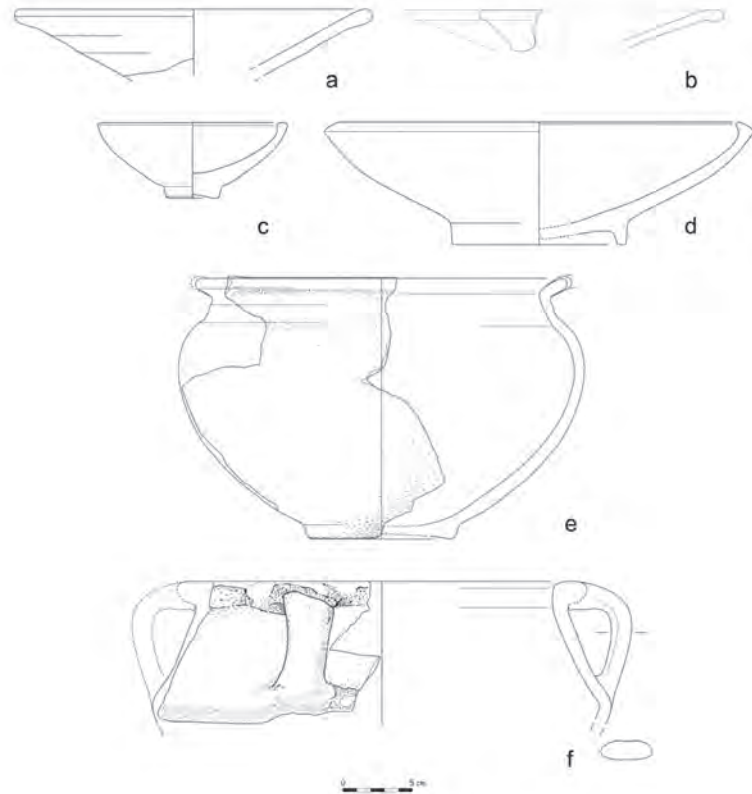

FIG. 4. Simple ware (SW) open shapes from Zincirli in the Iron Age IIB-III (courtesy the Chicago-Tübingen Expedition to Zincirli; drawings by M. Bartalini, M. Fraschi, S. Zagorski).

16 Struble – Herrmann 2009; Herrmann 2017b, pp. 294-297, tab. 2.

17 Soldi 2019, p. 175.

18 See Soldi 2019 and 2020.

19 See the discussion on the evolution of plates from the Middle Bronze Age and the relationships with late Hittite “drab ware” of Amuq Phase M at Chatal Höyük in Pucci 2019, pp. 173-177.

No.	Field N.	Class	Shape	Fabric Colour	Surface Treatment	Decoration
a	C10-1163	SW	Jug	2.5YR6/8 light red		
b	C17-65.43#6	CW	Cooking pot	2.5YR 2.5/1 Black	Polished	

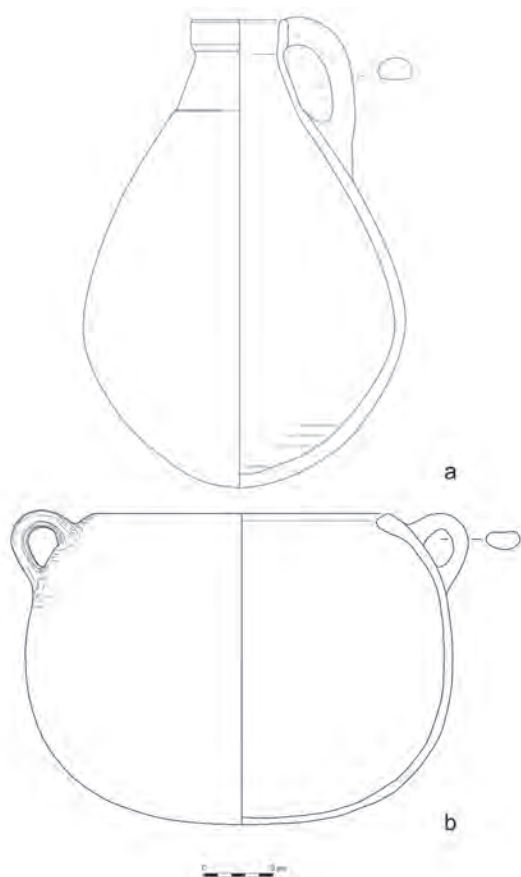

FIG. 5. Simple ware (SW) jug and hole-mouth cooking pot (CW) from Zincirli in the Iron Age IIB-III (courtesy the Chicago-Tübingen Expedition to Zincirli; drawings by S. Zagorski, C. Küncü).

its fall under the Assyrian influence coming from the east is definitely in place and marks the chronological horizon of Iron Age III.

At a regional level the pottery of Zincirli can be well compared with Sakçegözü on the north-eastern fringe of the Kara Su Valley and Taşlı Geçit Höyük on the south-eastern side, close to the area of the Yesemek quarries.<sup>24</sup>

on the citadel, whereas exemplars of the lower town seldom present a surface treatment.

Bowls show a larger variety of shape profiles and rims, stretching from large vessels for serving food to small size bowls for consuming it (FIG. 4.c-d). Less numerous but still well attested are large kraters with two or four handles (FIG. 4.e-f).

Closed shapes are jars and pear-shaped single-handled jugs with thickened lip (FIG. 5.a), a shape common throughout inner northern Syria from Hama to the Amuq.

Cooking pots are almost exclusively globular shaped hole-mouth vessel, with flat strap handle and thickened and elongated rim (FIG. 5.b).<sup>20</sup> The only cooking ware shapes other than hole-mouth pots are shallow plates and flat pans with thick walls and simple or pointed rim well attested in the region of İslahiye.<sup>21</sup>

Large pithoi with thick walls, biconical shape and swollen or angular rims are the dominant morphology for long-term storage ware.<sup>22</sup> It seems that this type of storage wares has more in common with the finds of the Ne-Assyrian period in the Euphrates area (namely Tell Ahmar and Karkemish) rather than with the “cigar-shaped” pithos of western Syria well attested between Tell Afis and Tell Mishrifeh/Qatna.<sup>23</sup>

The regional framework for Zincirli’s materials is thus the north Syrian one, though some peculiarities due to the northern location of the site and

20 Soldi 2019, pp. 172-173; see considerations from the perspective of Tell Afis in Mazzoni 2014, p. 356.

21 Soldi 2019, p. 173.

22 Soldi 2019, p. 174, fig. 9.

23 Mazzoni 2014, p. 356.

24 Sakçegözü: Du Plat Taylor – Seton Williams – Waechter 1950; Lehmann 1996; Taşlı Geçit Höyük: Marchetti 2011; Zaina 2013.



This horizon can be extended to other main sites of Northern Syria, the Amuq and the region of Aleppo, descending along the Orontes river down to Hama, Tell Mishrifeh/Qatna and Tell Nebi Mend. The overall picture is homogenous for the period of Iron Age II and III, with local productions of simple ware mainly consistent of open forms, plates and bowls, and hole mouth cooking pots, reflecting the main subdivisions of ceramic regions formerly proposed by the studies of Gunnar Lehmann and Stefania Mazzoni.

## 5. RED SLIP WARE AT ZINCIRLI

A significant issue for the local assemblage of pottery is the presence of the peculiar class of Red Slip Ware, which shares morphologies and fabrics with the overall inventory of simple common ware and which is the prominent trademark of the regional assemblages in the Levant in the Iron Age II.

In order to understand the impact of the Red Slip phenomenon at Zincirli, we have to bear in mind a series of factors: the nature of the archaeological record, the topography of the site and the chronological development of the settlement.

The first issue, namely the archaeological nature of the record, is related to specific problems of conservation affecting the artifacts. Extensive excavations in the Lower Town have recorded a huge amount of Iron Age pottery sherds, mostly characterized by a strong erosion and weathering of the surfaces. This issue has in some cases prevented a sound analysis of surface treatments, leaving some doubts whether a wash of clay engobe and/or a form of polishing or burnishing was actually employed on the interior and exterior face of the vessels. This is due to different physical factors: the nature of the soil, high in basaltic residuals in the ground exposed to extreme temperatures, associated to a high water table. As we pointed out above, the Kara Su Valley is extremely rich in water coming from the Amanus and Kurt Dağı mountains, and this could lead to the formation of extended marshes if the area is not regularly drained. This is the case for the northern lower town of Zincirli, as attested by the notes of the first German excavators at the site, who recorded the presence of a small nomadic settlement on the top of the hill, while the area surrounding the upper mound was partly occupied by marshes and muddy waters.<sup>25</sup> Even during modern excavations, the Chicago-Tübingen team had to face the high water springing from the trenches, thus preventing a deeper exploration of the layers in some areas, namely in the northern edge of the lower town.<sup>26</sup> Most of the pottery fragments collected from the field work in this area seems to be affected by the prolonged contact with water, associated to a highly erosive basaltic soil, conferring to most of the sherds a sort of underwater soaking aspect where traces of surface treatments have often been eroded or vanished. The situation is different on the citadel mound, where the quality of the ceramics materials is definitely improved, providing us with a better chance to collect information on the surface treatments, paintings and original aspect of the vessels.

This explanation could be at the base of the scarce presence of Red Slip in most of the lower town areas, but, as mentioned above, other factors should be taken in consideration. The first could be the topographic distribution of this class of pottery, which could be uneven throughout the whole site: a clear example of this issue is Tell Afis, which has provided one of the best and abundant documentation of Red Slip among North Syrian sites.<sup>27</sup> At Afis Red Slip is attested all over the excavated areas of the Iron Age II-III settlement, but its distribution is dramatically unequal, with specific contexts of the acropolis (Area G)

25 Wartke 2005, p. 19; indications of marshes (“Sumpf”) and watercourse (“Wasserlauf”) in the area surrounding Zincirli’s citadel can be spotted also on figs. 6 and 14.

26 Herrmann 2017b, p. 297.

27 Cecchini 1998.

No.	Field N.	Class	Shape	Fabric Colour	Surface Treatment	Decoration
a	C10-195	RS	Plate	2.5YR5/8 red	Slipped, burnished	2.5YR5/6 red
b	C11-20	RS	Plate	2.5Y7/3 pale yellow	Slipped	10R6/4 pale red
c	C08-83	RS	Bowl	7.5YR5/6 strong brown	Slipped	5YR6/8 reddish yellow
d	C11-118	RS	Bowl	2.5YR6/8 light red	Slipped	2.5YR6/8 light red
e	C12-140	RS	Bowl	7.5YR6/6 reddish yellow	Slipped	2.5YR5/8 red
f	C12-146	RS	Bowl	7.5YR7/6 reddish yellow	Slipped	2.5YR5/8 red
g	C13-64	RS	Bowl	5YR6/6 reddish yellow	Slipped, burnished	2.5YR5/8 red
h	C12-724	RS	Bowl	5YR6/6 reddish yellow	Slipped	7.5YR6/4 light brown
i	C12-500	RS	Bowl	7.5YR6/6 reddish yellow	Slipped	Red
j	C12-50	RS	Bowl (?)	5YR7/6 reddish yellow	Slipped	2.5YR5/8 red
k	C12-104	RS	Bowl	7.5YR7/4 pink	Slipped	Red
l	C12-675	RS	Krater	5YR6/8 reddish yellow	Slipped, burnished	2.5YR 4/6 red

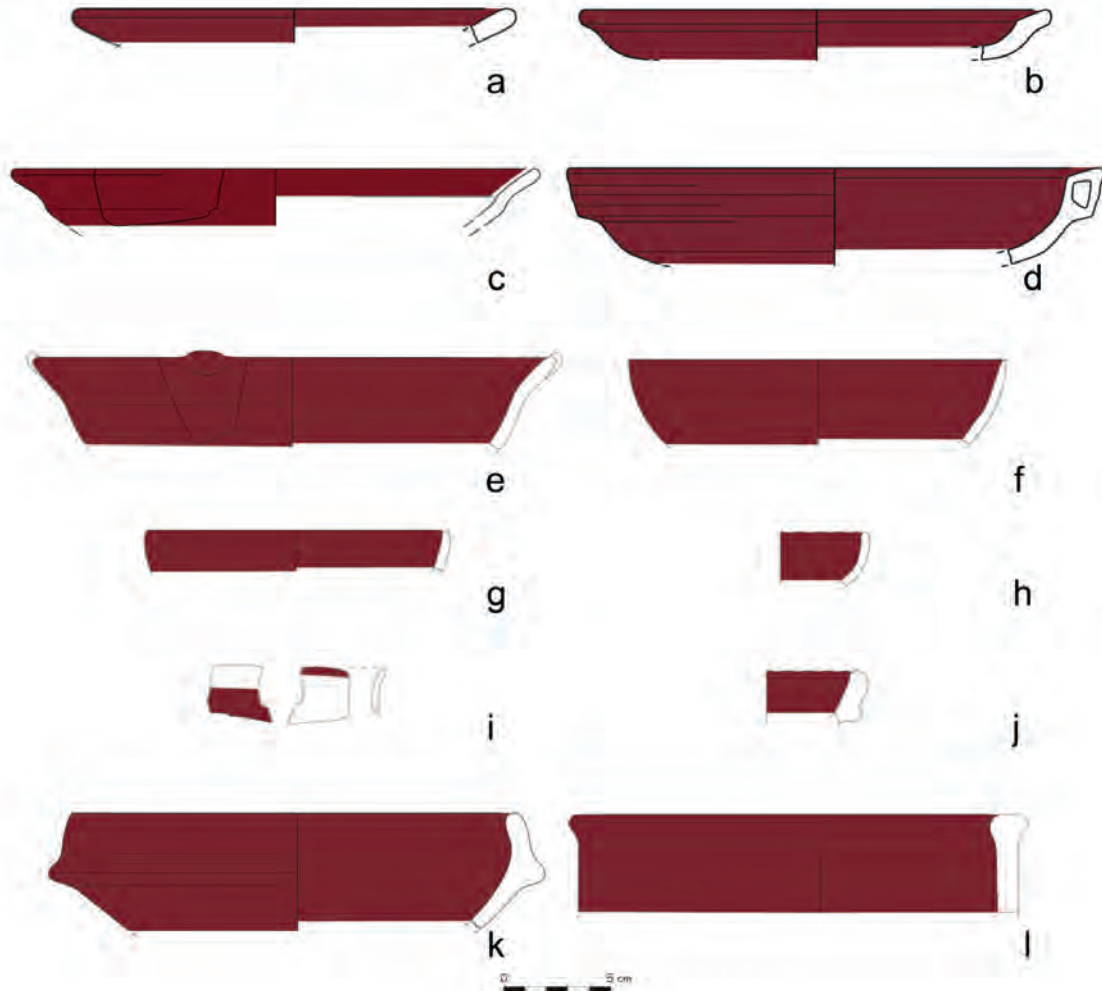

FIG. 6. Red Slip Ware (RS) from various areas in the Iron Age IIB-III (courtesy the Chicago-Tübingen Expedition to Zincirli; drawings by M. Bartalini, M. Fraschi, S. Zagorski, C. Küncü).

exceeding by far the sherds collected in the lower town.<sup>28</sup> We cannot thus exclude that also at Zincirli we may face an uneven distribution of specific class of materials between lower and upper town.

Recent excavations on the upper town have yielded a new abundant documentation of Red Slip, contrasting with the scarce and discontinuous documentation provided by the lower town. This issue finally offers new elements for a more balanced evaluation of the presence of RS at the site and in this northernmost fringe of the Levant.

The impression we gained from the first years of excavations was that Red Slip was a very sporadic class of pottery, known at Zincirli but not consistently employed in this settlement and surely underrepresented in comparison to other Northern Levant sites with a similar chronological framework. The items in the overall collection of hundreds of sherds in any archaeological feature (*locus*) excavated never reached a significant percentage, counting below 1% of the whole assemblage. The ratio was slightly more substantial in the upper citadel's Areas 2 and 3, but still in a fairly limited number. Shapes and fabrics of this minor collection are consistent with the overall assemblage of simple ware that we briefly highlighted, looking like a local production of the same ceramic workshops.

The evidence of Red Slip is entirely represented by open shapes with no jars or pitchers from the local slipped inventory: plates have simple rounded rims or everted rims as the most common profiles (FIG. 6.a-b). Bowls show a larger variety, with classical hemispherical bowls with simple rim (FIG. 6.f-h), biconical or carinated bowls with flaring rim (FIG. 6.c), in some cases with protruding knobs along the rib (FIG. 6.e); other shapes are deep bowls with folded thickened rim (FIG. 6.k), double thickened rim (FIG. 6.j) and deep bowls with rounded thickened rim (FIG. 6.l). A peculiar shape is a shallow hemispherical bowl with grooved squared rim and hollow on the inside (FIG. 6.d), which finds good parallels only in a 7th century BCE context from Chatal Höyük;<sup>29</sup> the vessel is slipped only on the inner side, but it cannot be excluded that the red engobe might have as well covered the exterior face. Only a few other non-diagnostic body sherds from the lower and upper town were collected until when the South-West sounding in Area 3 started providing a different set of materials.

This picture has dramatically changed during the very last campaigns at the site, when in 2018 a sounding in Area 3 on the southern Citadel has reached the earliest Iron Age strata in that sector of the upper mound. The South-West Sounding, a probe of 3 by 2 meters, is unfortunately too limited to offer a paradigmatic reconstruction of the bigger picture, but an overall change in the material culture is nevertheless clearly perceptible. It has been labelled as Phase 9, lying underneath Phase 8 and the silo of Phase 7, which contained fragments of Assyrian Palace Ware mixed with local Iron Age II-III sherds. Phase 9 should thus belong to an earlier phase of Iron Age II (IA IIA), with several fragments of Red Slip Burnished and a few examples of Cypro-Geometric pottery.<sup>30</sup>

The limited extension of Area 3's Phase 9 dug in 2018 and 2019 provided a total amount of 206 diagnostic sherds.<sup>31</sup> This sample offers proportions of materials completely different from later IA strata: 34% of the pottery collected is common IA ware, 32% is red slipped and burnished covering two thirds of the whole assemblage. The rest of the collection includes Black-on-Red (3%), Cypriot painted wares (White Painted and Bichrome for an amount of 4%), hole-mouth cooking-pots (5%), storage ware (1%) and several fragments of Bronze Age vessels (EBA 15%, MBA 2%). Another interesting data is the presence of some sherds of IA painted common ware (4%), not identifiable as Red Slip neither as other "imported" wares (such

28 Soldi 2009, p. 103; 2013.

29 Pucci 2019, pl. 132.k.

30 Excavations in this Area were supervised in 2018 by Barbara Bolognani and in 2019 and 2021 by Virginia R. Herrmann.

31 This number includes only the number of diagnostic sherds (rims, bases and handles) analyzed in campaigns 2018 and 2019 from selected *loci* of Phase 9 that were not contaminated by later pits.

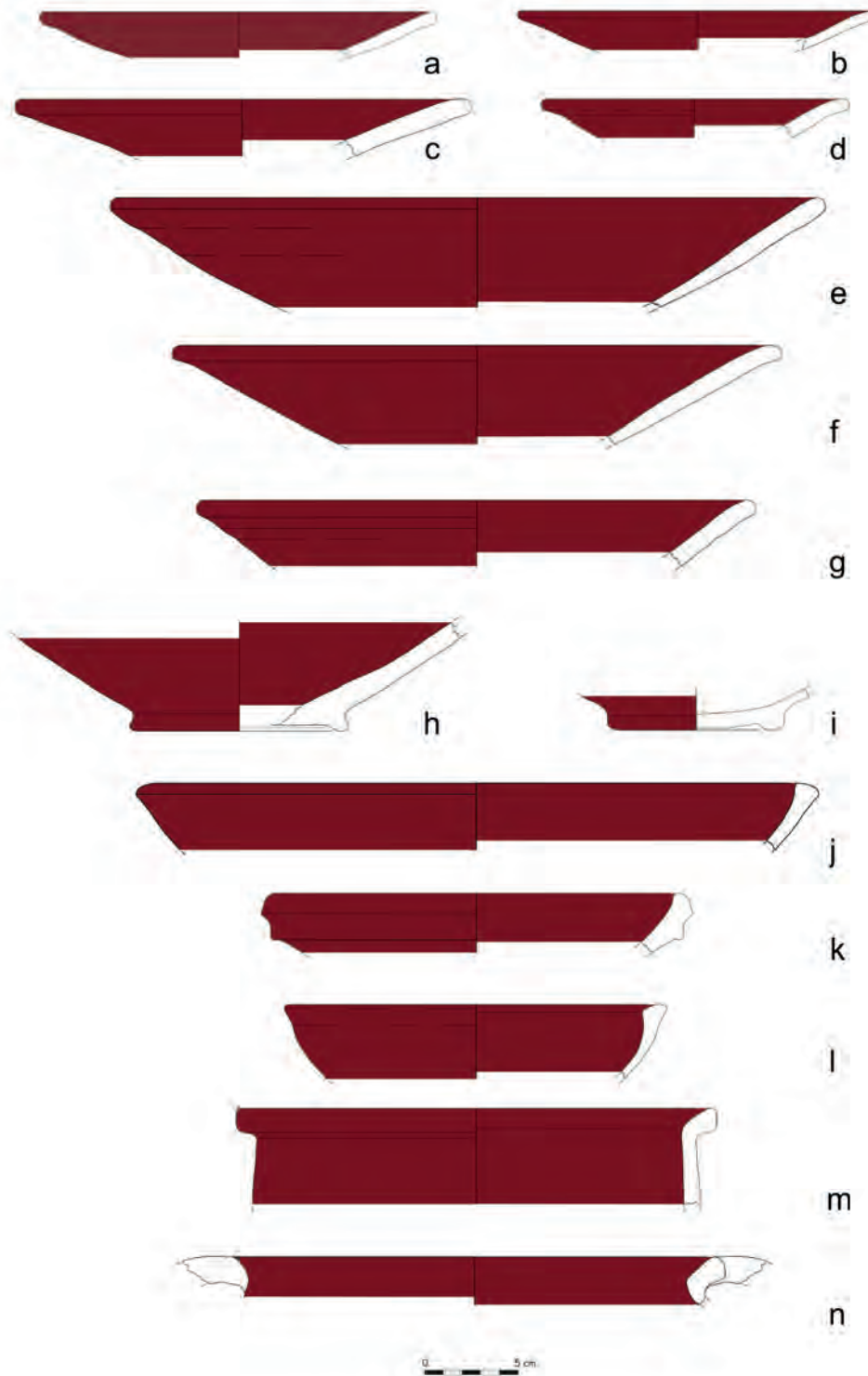

FIG. 7. Red Slip Ware (RS) open shapes from Area 3, Phases 9 and 8 (courtesy the Chicago-Tübingen Expedition to Zincirli; drawings by C. Küncü).

No.	Field N.	Class	Shape	Fabric Colour	Surface Treatment	Decoration
a	C18-190	RS	Plate	5YR5/6 yellowish red	Slipped, burnished	5YR5/6 yellowish red
b	C18-196	RS	Plate	2.5YR6/8 light red	Slipped, burnished	5YR6/6 reddish yellow
c	C18-188	RS	Plate	5YR5/6 yellowish red	Slipped, burnished	2.5YR5/8 red
d	C19-17	RS	Plate	2.5YR6/6 light red	Slipped, burnished	5YR5/4 reddish brown
e	C18-316	RS	Plate	5YR4/3 5YR5/4 reddish brown	Slipped, burnished	2.5YR5/8 red
f	C18-284	RS	Plate	5YR5/6 yellowish red	Slipped, burnished	5YR5/4 reddish brown
g	C18-194	RS	Plate	7.5YR5/3 brown 2.5Y5/6 red	Slipped, burnished	5YR5/4 reddish brown
h	C18-320	RS	Plate	7.5YR5/3 brown 7.5YR6/6 reddish yellow	Slipped, polished	10R5/8 red
i	C19-50	RS	Plate / bowl (?)	10R5/8 red	Slipped, polished	10R5/8 red
j	C19-18	RS	Bowl	2.5Y4/6 red	Slipped, burnished	2.5Y4/8 red
k	C19-35	RS	Bowl	5YR6/4 light reddish brown	Slipped, burnished	7.5YR6/4 light brown
l	C19-9	RS	Krater	2.5Y4/8 red	Slipped, burnished	2.5Y4/8 red
m	C18-309	RS	Bowl	2.5YR6/8 light red 5YR5/6 yellowish red	Slipped, burnished	2.5YR5/6 red
n	C19-7	RS	Krater	5YR5/6 reddish yellow	Slipped, burnished	2.5YR5/8 red

No.	Field N.	Class	Shape	Fabric Colour	Surface Treatment	Decoration
a	C19-14	RS	Jug	2.5YR5/8 red	Slipped, burnished	2.5YR5/6 red
b	C19-49	RS	Jug	2.5YR5/8 red	Slipped, burnished	2.5YR5/6 red
c	C18-291	RS	Spouted jar (?)	2.5YR4/8 red	Slipped, burnished	2.5YR4/8 red
d	C18-275	RS	Jar (?)	2.5YR5/8 red	Slipped, burnished; incised	2.5YR5/8 red
e	C18-279	RS/StW	Pithos	2.5YR6/6 light red	Slipped, burnished	2.5YR5/8 red

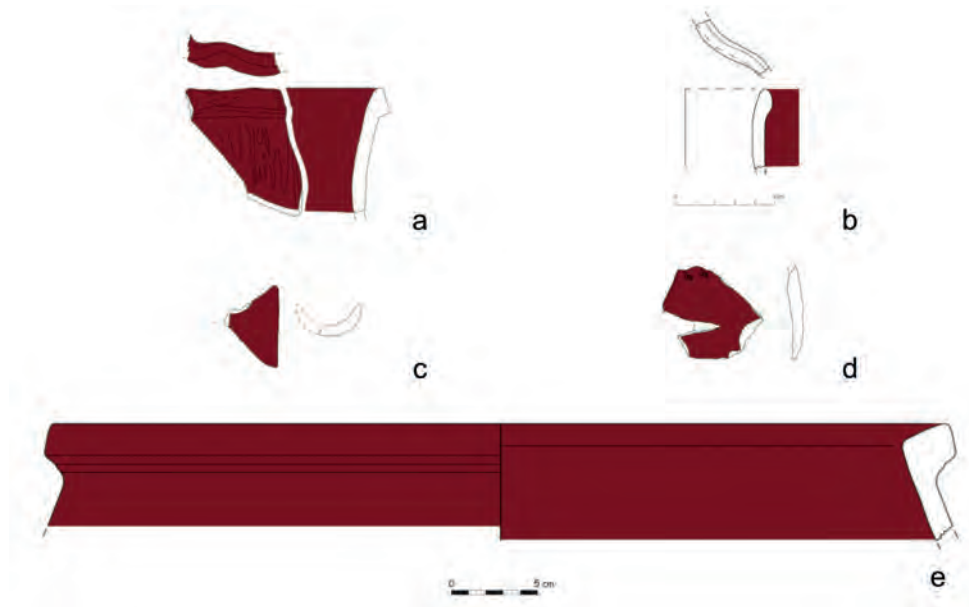

FIG. 8. Red Slip Ware (RS) and storage ware (StW) closed shapes from Area 3, Phases 9 and 8 (courtesy the Chicago-Tübingen Expedition to Zincirli; drawings by C. Küncü).



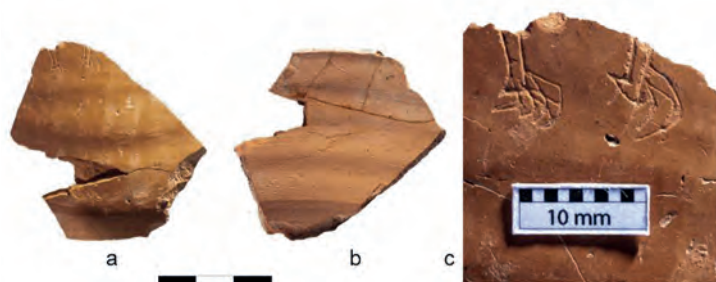

FIG. 9. The fragment of Red Slip burnished C18-275 (Fig. 8.d) with incised decoration (courtesy the Chicago-Tübingen Expedition to Zincirli; photo by R. Ceccacci).

as Cypriot),<sup>32</sup> a data which also stands out in comparison with the almost complete absence of painted ware in later IA II-III inventories.

Though we need to stress on the limited extension of the probe and the not yet clear architectural and functional destination, we notice that the percentage of 32% of Red Slip ware (plus the number of Black-on-Red, which can be sometimes confused with RS) is a data completely different and unexpected at the site. The concentration of red slipped sherds is extremely high compared to the low percentages of any other areas at the site. A possible explanation to this issue shall be sought in the different chronological horizon, predating the IA II-III horizon widespread at the site, probably associated to the functional destination of the area, though this could only be ascertained by widening the exposed surface by further excavations.

Even from this context on the upper mound the range of morphological variations associated to the red slip treatment is fairly limited. Shapes from this lot are mostly large plates with simple rounded rim and ring bases, ranging from mid-size to large-size plates with diameters between 20 and 30 cm (FIG. 7.a-i). Bowls are well attested but less numerous than plates, with shapes of large bowls with thickened, everted or double rim (FIG. 7.j-l). Some large kraters with everted angular rims and handles are also attested (FIG. 7.m-n). Closed shapes are extremely rare, confirming the general trend of this assemblage throughout the northern Levant.<sup>33</sup> Among the few closed vessels attested in red slip are two specimens of trefoil-rim jugs (FIG. 8.a-b), the first with a peculiar triangular rim which is well attested in the late Iron Age I and early Iron Age II (IA IIA).<sup>34</sup>

A fragment of red-slipped and burnished spout testifies to the presence of a spouted jar, as attested in the Amuq at Chatal Höyük (FIG. 8.c). One single sherd of body belonging to an unidentified closed shape has a peculiar graffito representing the paws of a bird (bird of prey or fabulous monster) with no other known comparison on ceramics (FIG. 8.d). The incision has been made after the firing, by incising the thick layer of glossy red engobe (Fig. 9).

One single fragment of Red Slip storage jar pithos with everted and inner angular rim is attested (FIG. 8.e). This is a peculiar case, since RS is extremely rarely associated with storage ware, not only at Zincirli but as a general case all over the Northern Levant.

A specific trait of the Red Slip Ware from Area 3 level 9 is the combined thickness and brightness of the slip. The engobe is carefully laid on the surfaces of the vessels, both on the inside and outside faces (of open shapes), associated to a careful burnishing of the surface, which is almost always carried out horizontally.<sup>35</sup> Though no complete vessel has been recovered from the trench, it seems that the body of the vases was slipped all over its surface, and not covered only in some parts like the areas close to the rim, as it happens

32 With term “Cypriot” we refer here to items which can be ascribed to the painted wares known in the Cypro-Geometric and Cypro-Archaic horizons (Black-on-Red, Bichrome, White Painted), but could be manufactured in other areas of Western Asia, such as Cilicia or Amuq/Hatay and not specifically in Cyprus (see recently the article of Karacic – Osborne 2016 on this issue related to the documentation of Tell Tayinat).

33 Soldi 2013; Pucci – Soldi 2019.

34 Venturi 2007.

35 Only one case (C19-44) at Zincirli presents the double burnishing (vertical on external side and horizontal on internal side). At Chatal Höyük the opposite feature (horizontal on external and vertical on internal) is recorded on some items of conical plates (cf. Pucci – Soldi 2019, p. 353).

No.	Field N.	Class	Shape	Fabric Colour	Surface Treatment	Decoration
a	C18-55.68#2	BoR	Bowl	2.5YR6/6 light red	Slipped, burnished, painted	2.5YR5/8 red+ black
b	C18-186	BoR	Bowl	2.5YR6/8 light red	Slipped, burnished, painted	2.5YR6/8 light red + black
c	C18-292	BoR	Bowl	2.5YR6/8 light red	Slipped, painted	2.5YR6/8 light red + black
d	C18-187	WP	Bowl	10R7/6 red 7.5YR6/4 light brown	Painted	Black
e	C18-315	WP	Barrel Jug (?)	2.5YR8/4 pale yellow	Painted	10YR3/2 very dark grayish brown
f	C18-306	Bichr.	Bowl	2.5YR4/8 red	Painted	2.5YR6/6 light red 2.5YR2.5/2 very dusky red

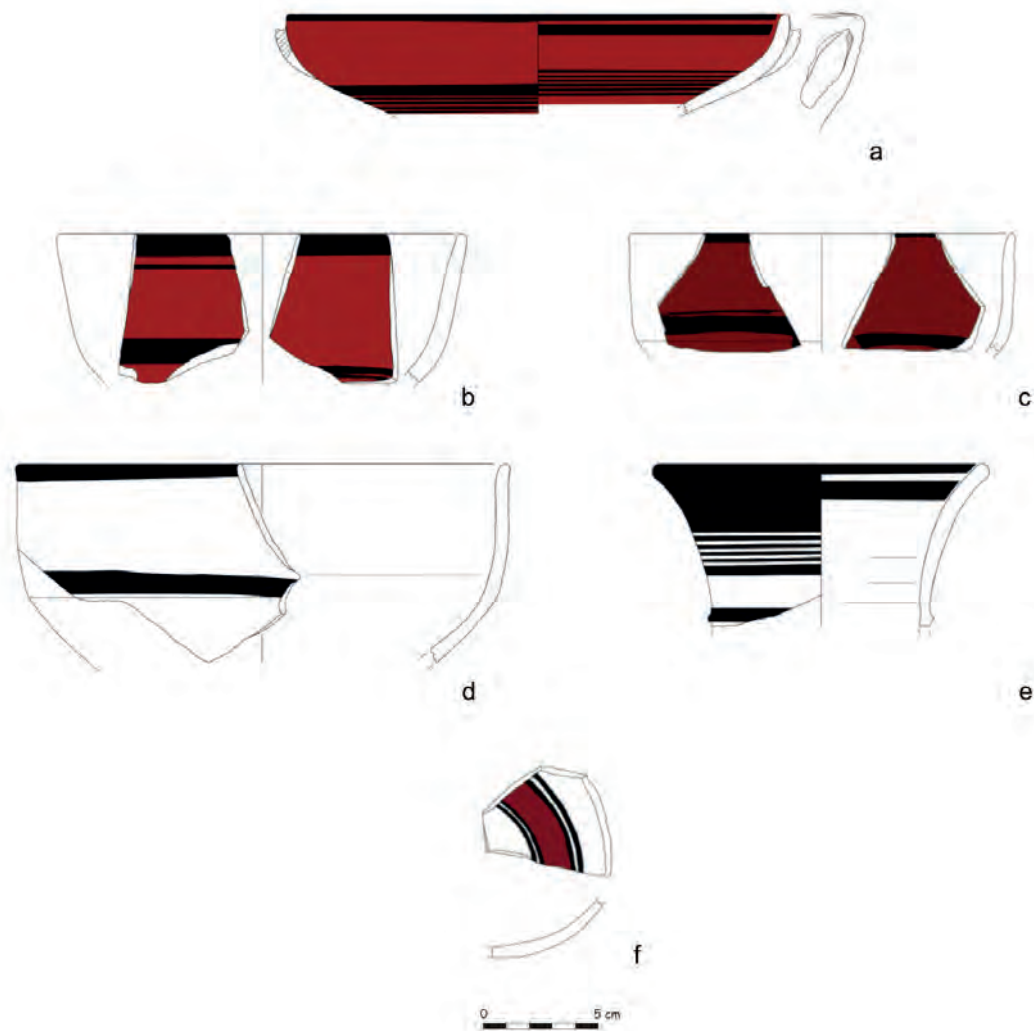

FIG. 10. Black-on-Red (BoR), White Painted (WP) and Bichrome (Bichr.) Cypriot-style pottery from Area 3, phases 9 and 8 (courtesy the Chicago-Tübingen Expedition to Zincirli; drawings by C. Küncü).

with many items from north Syrian sites.<sup>36</sup> The thick and dark red painting is also contrasting with the few red slipped items recovered from other areas of the site, namely those in the lower town.

### 5.1. *Cypriot-style Ware in Area 3*

We need to stress how another relevant group of pottery from the same *loci* in Area 3 levels 9 and 8 belongs to painted wares of Cypriot styles. These are Black-on-Red (FIG. 10.a-c), White-Painted (FIG. 10.d-e) and Bichrome bowls and jugs (FIG. 10.f). Apparently Black-on-Red fragments present a similar red slip burnishing on the surface, but the carefully black painted concentric lines and the brittle red fabric reveal that they belong to a different workshop. Though a few cases appear to be very similar, the well fired and tempered fabric slightly different from the common and Red Slip assemblage, point towards imports from other regions, most likely from Cilicia, the Amuq or Cyprus itself.

Even for the Cypriot-style vessels, the inventory of shapes consists mostly of open shapes (bowls and skyphoi), largely outnumbering the fragments of jugs and juglets, thus being a close functional companion to the Red Slip vessels (FIG. 10).<sup>37</sup>

The issue of the origin of Cypriot-styles vessels in southeastern Anatolia has been recently approached by Steven Karacic and James Osborne through the employment of pXRF and NAA analysis on the lot of the Amuq documentation excavated in the 30's by the Chicago Syrian-Hittite Expedition and stored at the OI of the University of Chicago.<sup>38</sup> The results of this inquiry revealed that White-Painted and Bichrome ceramics locally produced in the Amuq and those directly imported from Cyprus are macroscopically undistinguished, and that both are well attested at the Amuq sites, with a majority of items directly coming from the island.<sup>39</sup> Also, it seems that the capital of the kingdom of Patina, Tell Tayinat/Kunulua, records the presence of both artifacts, whereas second level sites in the political hierarchy of the region (such as Tell Judeideh and Chatal) only record items from Cyprus itself. Equally interesting is the fact that the Amuq samples are either locally produced or imported from Cyprus and none seems to be imported from Cilicia, where kilns producing Cypriot-style vessels have been excavated at Tarsus and at Kinet Höyük.

Zincirli's Cypriot-style materials have been analyzed so far only through stylistic and macroscopic observations,<sup>40</sup> revealing differences from the local simple ware and Red Slip assemblages. Analysis on the clay sources could help in detecting the possible origin for the Cypriot-style vessels, which we currently believe to have been imported at the site. It is uncertain whether the vessels were produced in Cyprus or in Cilicia or the Amuq, and also which might have been the path to reach Zincirli either from Cilicia through the Amanus gates or from the Amuq through the Kara Su Valley.

The chronological range of these vessels spans from the Cypro-Geometric III to the Cypro-Archaic I (ca. 900-600 BCE).<sup>41</sup> We can confidently state that the impact of Cypriot-style ware is higher in Area 3's levels 9 and 8 (local Iron Age IIA-B) and diminishes in the overall assemblage of Iron Age III lower town's excavation areas, following the same trend as Red Slip Ware. While we cannot establish a direct relationship with historical facts and changes in the socio-economic patterns, we observe that after the inclusion of Sam'al

36 See several examples at Tell Afis in Soldi 2013, figs. 1-4 and Cecchini 1998.

37 One neck and rim fragment of White Painted ware (FIG. 10.e) could likely belong to a barrel jug.

38 Karacic – Osborne 2016.

39 Karacic – Osborne 2016, pp. 13-14.

40 The Chicago-Tübingen Expedition is currently applying for permits to conduct analysis on the materials kept in the expedition's storehouse, and we wish to carry them out in one of the next study seasons at Zincirli.

41 Karageorgis 2000, p. 77.

in the Assyrian empire in the second half of the 8th century BCE Cypriot-style/Cypriot-imported wares decrease while a larger mass-produced standardized simple ware increases.<sup>42</sup>

## 6. CHRONOLOGY AND REGIONAL FEATURES

The chronology of Zincirli's Red Slip Ware falls with no doubt in the range of the Northern Levant Iron Age II and III subdivision (FIG. 3).

We can clearly outline two groups of Red Slip Ware following Zincirli's documentation. The first one comes from Area 3's loci belonging to Phases 9 and 8. Its main characteristics are the dark red and thick slip and burnishing, mostly associated to conical plates with simple rounded rims and shallow bowls with slightly thickened rim. It can be ascribed to an earlier horizon of Iron Age IIA-B (9th to mid 8th century BCE), also in association with other finds.<sup>43</sup> The second group has been identified in the lower town's Areas 5 and 6 and in upper town's Area 3 (Phases 7 to 4). As already stressed, Red Slip in these contexts is much less attested and, generally speaking, the manufacture is a bit different: the slip is less dark and thick, but still burnished. Given the scarce number of sherds, it is hard to define a coherent morphological typology, but different kinds of open vessels are attested, probably more influenced by the presence of Assyrian shapes at the site. Chronologically this group can be assigned to a local Iron Age III horizon (mid 8th to 7th century BCE).

The second group can be well compared with the lot of Iron Age III materials from the nearby site of Taşlı Geçit Höyük, on the road between Tilmen Höyük and the Yesemek Hittite quarry, where a rescue expedition of the University of Bologna has excavated a Middle and Late Bronze Age settlement reoccupied during the late Iron Age.<sup>44</sup> Taşlı Geçit Höyük shares with Zincirli the overall assemblage of the Assyrian period, comparable in terms of simple ware, cooking pots and storage ware.<sup>45</sup> Even at Taşlı Geçit Red Slip burnished is recorded, sharing shapes and types with the inventory of common simple ware.<sup>46</sup> It is worth to stress on the close similarity of these two sites, which share features of a common material culture during the globalized context of the Assyrian empire. It is also remarkable to confirm the presence of red slipped ware at Taşlı Geçit Höyük offering a consistent picture of the İslahiye Valley as a corridor connecting north-south the Amuq and northwestern Syria with the Taurus plateau and southeastern Anatolia. On the other end of the valley, northwest of Zincirli, Sakçegözü, well known for its late Iron Age monumental building with sculptures influenced by Neo-Assyrian art, also provide some elements in Level X belonging to the same cultural and chronological horizon.<sup>47</sup>

In the bordering regions north and east of Sam'al, Red Slip is attested at various sites on the Euphrates. Karkemish presents some common features with Zincirli's Iron Age material culture, especially in its latest Iron Age III/Neo-Assyrian period.<sup>48</sup> Though not extremely abundant, Red Slip ware is present in Iron Age II layers at the site, reaching its highest percentage of 17% in Level 10 of Area G in the inner lower town, and then gradually decreasing until disappearing in Iron Age III.<sup>49</sup> In the mid-Euphrates region the presence of Red

42 On the overall assemblage of Zincirli in the Iron Age III and the impact of few other classes of imported pottery (Cypriot, Phoenician/Coastal Syria, Assyrian), see Soldi 2019.

43 Fragments of jars with thickened rim and painted band on the lip in the late IA I – early IA II of Northern Syria (Afis, Hama) and unbaked clay cylindrical loom weights deriving from the IA I tradition.

44 Marchetti 2011; 2012.

45 Zaina 2013; parallels in the assemblages of simple ware between the two sites have been addressed in Soldi 2019.

46 Zaina 2013; Pucci – Soldi 2019, pp. 357-358.

47 Du Plat Taylor – Seton-Williams – Waechter 1950; Lehmann 1996, pp. 220-221, Taf. 100.

48 Bonomo – Zaina 2014; Marchetti 2014; Pizzimenti – Zaina 2016; Zaina 2019.

49 Zaina 2019, pp. 125-26, 138.

Slip is spotty and irregular, reaching less than 2% in Area F-Period IX and Area G of Tell Shiukh Fawqani.<sup>50</sup> A similar pattern is present at Tell Ahmar, where Red Slip is not abundant as well, but can be found within the complex of the Assyrian houses of Area C.<sup>51</sup> Following the river upstream, at Tille Höyük this class of pottery is still attested, but never in large quantities, both in the Middle Iron Age level and in the Neo-Assyrian one.<sup>52</sup> Surprisingly at Arslantepe/Malatya, further north, a recently excavated Iron Age II context has produced abundant documentation of Red Slip, roughly estimated as 30% of the pottery production from this phase.<sup>53</sup>

Though we must be extremely careful in referring to exact percentages, especially when contexts are not totally secure and providing a closed inventory, we may notice a similar trend of some Euphrates sites with the high percentage of Zincirli's Area 3 (30% of the whole assemblage, similar to Arslantepe in IA II), and the dramatic decrease in the following period (less than 1% in Zincirli's lower town, similar to Karkemish and Tell Shiukh Fawqani in the IA III). If this is confirmed, we may assume that Red Slip is partially abandoned in this northern area at the end of the 8th century BCE and during the period of Assyrian domination. This phenomenon is not reflected by a macroscopic change in the utilitarian ceramic inventory, which remains very similar, but by the disappearance of Red Slip and the appearance of shapes and treatments (glazed items and Palace Ware) which seem to be a typical North-Mesopotamian feature.

The Kara Su Valley is naturally connected to the Amuq region, where the rivers of Kara Su, Afrin and Orontes flow and convey. Though a marshy area (later turning into a proper lake) was attested north of Antioch,<sup>54</sup> contacts and circulation with the northern fringe of the Kara Su Valley were consistent both in the Bronze and Iron Age. This feature is reflected in the similarity of Zincirli's assemblage with Tell Tayinat's and Chatal Höyük's material culture in the Iron Age II and III. The plates with straight walls and simple rounded rim common in Zincirli's Area 3 phases 9/8 have the same features of the conical plates of Tell Tayinat's Field 2/Phase 4 (Building XIV, dated late IA I – early IA II)<sup>55</sup> and of Chatal Höyük's Phase O\_Beginning and O\_Middle,<sup>56</sup> establishing a useful chronological parallel. At both sites Red Slip Burnished Ware continues to be produced and used throughout the period, until the Neo-Assyrian phase.

In northwestern Syria Red Slip Ware is part of the local assemblages of Iron Age pottery. It is a clear mark in the horizon of ceramic productions of Iron Age II and III, attested at every major site in the region. It is attested over a vast region, from Tell Rifaat (ancient Arpad) and Tell Abu Danne in the areas north and east of Aleppo, to the Idlib countryside at Tell Afis, Tell Mardikh, Tell Tuqan, Tell Denit and Tell Mastuma, until further south to Hama and Tell Acharneh and Tell Mishrifeh/Qatna in the region of Homs.<sup>57</sup>

It is especially at Tell Afis, ancient Hazrek capital of Lu'ash in the kingdom of Hamath, that Red Slip has been attested throughout different areas of the site and excavated in different archaeological contexts.<sup>58</sup> Red Slip has been recovered from any excavation area which has revealed an Iron Age II-III occupation, but great majority of the items were collected on the mound's acropolis, especially in Area G, where the imposing square structure on the eastern side of the acropolis revealed hundreds of large fragments of slipped and burnished ware.<sup>59</sup>

50 Luciani 2005; Makinson 2005, p. 465.

51 Jamieson 1999 and 2000.

52 Blaylock 2016, p. 6.

53 Manuelli – Pittmann 2018, pp. 155-156.

54 Osborne 2013, pp. 777 and fig. 2, 780.

55 Osborne *et al.* 2019, p. 277, fig. 13.1-6.

56 Pucci 2019, pp. 186-187; Pucci – Soldi 2019, p. 353, fig. 2.a-g.

57 See Soldi 2019, p. 176 with full bibliographic references.

58 Oggiano 1997; Cecchini 1998; Soldi 2009; 2013; Mazzoni 2014; Venturi 2020.

59 Cecchini 1998 and 2000.



The core of Afis' Red Slip documentation belongs to an advanced stage of Iron Age, mostly end of IA II and IA III, but its appearance at the site must have happened around the mid or second half of 9th century BCE, when the tradition of painted wares and imitation of Aegean models typical of IA I gradually came to an end and was substituted by the standardized and mass-produced common orange ware horizon and by red-burnished ware.<sup>60</sup>

Petrographic analyses conducted over a sample of Tell Afis' materials show that common orange ware and Red Slip were manufactured with the same local sources of clay and presented similar technological and firing features, except for the use of engobe on the surface of Red Slip.<sup>61</sup> Nevertheless the analyzed sample reveals two distinguished groups of Red Slip Ware: both of them were locally manufactured at the site, but they differ in composition of the slipped engobe and for the firing. It does not seem that we can link this issue to any chronological relationship, but likely the difference implies a different functional choice or use during communal consumption of food. Whereas type A is more abundant and characterized by a bright red colour obtained by quartz, calcite and hematite, vessels of type B are characterized by a thick dark reddish-brown burnished slip obtained by hematite, probably ashes and a higher firing temperature.<sup>62</sup> This second type usually covers the whole surface of the vessel both inside and outside, as it was found in large quantity in the filling layers of Area G squared building L.1344, together with great amounts of animal bones and ashy deposits indicating some sort of communal feasting.<sup>63</sup>

Finally another element emerging from the outstanding Afis documentation is the almost exclusive red slipped and burnished treatment for open shapes, with very minor appearance on jars and jugs or other sort of closed vessels, an element which sets the standard for the difference between the Northern Levant with the southern Levant and Phoenicia, where also closed forms were frequently slipped and burnished.<sup>64</sup>

Tell Afis is the key site for the documentation of Red Slip in Iron Age inland Syria. Shapes, classes and patterns of its material culture can be identified in many sites of the region, giving shape to a rather unified group of materials which have their centers in Afis and Hama, capital of the kingdom of Hamath and Lu'ash. Hama was the major site of inland central Syria, controlling the routes along the Orontes and the east-west crossings between the Mediterranean and the Syrian desert and the middle Euphrates, thus establishing a powerful area of control between the major centers of Aram-Damascus and the kingdoms of Patina in the Amuq and of Arpad in the region of Aleppo.

The material culture of Hama E is therefore well comparable with Afis/Hazrek in IA II and III.<sup>65</sup> Other sites sharing communal traits and uniformity in a regional consistent group where common orange ware and Red Slip ware show similar peculiarities, are Tell Mardikh/Ebla,<sup>66</sup> Tell Tuqan,<sup>67</sup> Tell Mastuma,<sup>68</sup> Tell Denit<sup>69</sup> all in the close vicinity of Afis. Closer to Hama or connected to the capital via the Orontes river

60 Soldi 2013, pp. 200-201; Mazzoni 2014, pp. 359-360; Venturi 2020, pp. 113-114.

61 Falcone – Lazzarini 1998, pp. 487-488.

62 Falcone – Lazzarini 1998, p. 488.

63 Soldi 2013; Mazzoni 2014, p. 350.

64 As an example, see Lehmann 2015 and Stern 2015.

65 Fugmann 1958; Riis 1990.

66 Mazzoni 1992; Pizzimenti 2014-2015.

67 Fiorentino 2006 and 2014.

68 Wada 1994; Wakita *et al.* 1994; Wakita – Wada – Nishiyama 2000; Iwasaki *et al.* 2009.

69 Rossi 2011.

are Tell Qarqur,<sup>70</sup> Tell ‘Acharneh,<sup>71</sup> Tell Khan Sheikoun,<sup>72</sup> and southwards Tell Mishrifeh/Qatna<sup>73</sup> and Tell Nebi Mend.<sup>74</sup>

One last area strictly connected to the Northern Levant is Cilicia, in the northeastern corner of the Mediterranean. Cilicia is a peculiar environment with its rural and mountainous countryside of Plain and Rough Cilicia and at the same time an intense set of overseas relationships, expanding to Cyprus, Phoenicia and west Anatolia. Red Slip ware is part of the assemblages of sites where Iron Age layers have been excavated, and specifically at Kilise Tepe, Tarsus/Gözlükule, Sirkeli Höyük, Misis Höyük, Karatepe-Aslantaş and Kinet Höyük. Since we cannot include here a detailed analysis of Cilician sites, where a major revision and reassessment of local chronologies based on new stratigraphic data is under construction,<sup>75</sup> we will only state how Red Slip is often associated with Cypriot-style vessels (CG III and CA I) and finds its first appearance in the 9th century BCE, reaching its peak in the 8th century and starting to decrease in the 7th century.<sup>76</sup>

#### 7. RED-SLIPPED AND BURNISHED VESSELS AS SKEUOMORPHIC DEVICES?

As we have seen above, Red Slip Ware shares its morphological and technological features with most of the local common simple ware assemblages. When petrographic analyses are conducted, they reveal a local production sharing clay and temper with the overall local pottery horizon.<sup>77</sup> However this does not explain why certain vessels were slipped (and burnished) and others, which shared the same shape and fabric, were not.

The “skeuomorphic” explanation is surely a possible one, which is the replication of an object into a different material medium.<sup>78</sup> The shape and the function of the object remains similar to the original model, but its materiality is entirely transformed, in order to reproduce the item in a faster and cheaper “chaîne opératoire” without losing the relationship with the imitated good. Thus, Red Slip vessels would be an imitation of containers which were also produced in bronze, a material much more expensive because of long-distance trade of tin and copper and more complicated in manufacturing rather than the ubiquitous clay for pottery production.<sup>79</sup> The juxtaposition of a clay engobe (from a lighter wash to a thicker and glossy covering) would have ensured a light-to-dark red-brownish aspect partially recalling a bronze surface. This

70 Dornemann 2000.

71 Cooper 2006.

72 Du Mesnil du Buisson 1932, p. 179, pl. XXXVII.205.

73 Besana – Da Ros – Iamoni 2008; Morandi Bonacossi 2009; Russo 2018.

74 Whincop 2007.

75 See the results of recent ongoing workshops on Cilician chronology: Novák *et al.* 2017.

76 See recent overviews of Iron Age assemblages for Misis (D’Agata 2019, pp. 89-91, figs. 4.d, 10.c, attesting red slip ware in phases 11 and 10 of local IA II), Sirkeli (Kulemann-Ossen – Mönninghoff 2019, tracing the presence of red slip wares already in phase D9 belonging to late IA I and then increasing in the IA II and extremely rare in IA III) and Kinet (Lehmann 2008 and 2016, analyzing the material culture in the Iron Age and during the Neo-Assyrian period).

77 See the case of Tell Afis (Falcone – Lazzarini 1998), but also the productions of Cypriot-style vessels locally produced in the Amuq (Karacic – Osborne 2016) and in Cilicia (D’Agata 2019, pp. 103-106, addressing the relevant question of the transfer of the technological know-how in reproducing locally a foreign product). On the local productions of Red Slip in the Amuq, at Chatal Höyük and al-Mina, see Pucci 2020, p. 23 and note 105.

78 O’Hara 2012.

79 Whincop 2009, p. 225; see the discussion in Pucci 2019, p. 159 about an unfunctional pouring vessel in red burnished pottery from Chatal Höyük, imitating in clay metal prototypes from Cyprus, Northern Syria (Tell Halaf) and Mesopotamia (Nimrud): such shape is attested as well on the Karatepe reliefs, surely reproducing a metal pouring vessel (Orthmann 1971, Taf. 18.c (Karatepe B/1); see also Stronach 1995, pp. 185-187, fig. 12.6.a-b).

is especially the case for bowls, and more specifically for bowls covered in their entirety by a thick dark red burnished slip, recalling shapes of metal bowls well attested in the Levant, in Anatolia and Cyprus.<sup>80</sup>

If this is the case, the symbolic value of specific vessels to present and consume food must have been part of social communal practices of feasting, and Red Slip did play a part in the banqueting habits in Aramaean and Luwian elites communities in this area of the northern Levant.<sup>81</sup>

Though Zincirli's Red Slip ware documentation is not sufficient to build a paradigmatic interpretation, it is nevertheless worth to stress that ancient Sam'al was surely one of North Syria's bronze working centre active in the Iron Age.<sup>82</sup> Bronze vessels (bowls and *phialai*) had a prominent role for specific cultic or official banquets, as the recent Katumuwa's mortuary stele testifies by reproducing the dead holding a gadrooned metal bowl,<sup>83</sup> but we can hypothesize that open slipped and burnished vessels were usually employed for activities of communal food consumption in the Iron Age II.

## 8. CONCLUSIVE REMARKS

The recent ceramics documentation from Zincirli offers a new piece of the puzzle to our knowledge of material culture and, consequently, of socio-economic relationships in the Iron Age Northern Levant.

The archaeological and stratigraphic context of Red Slip Ware from the upper mound of the site enables us to establish a more coherent chronological framework. Though limited and still in need for a complete stratigraphic reassessment (see FIG. 3), the sounding in Area 3 in the eastern citadel provides a set of materials, including Red Slip and Cypriot-style vessels, which predate the Assyrian control over the kingdom of Sam'al and that can be dated in the Iron Age IIA. In terms of absolute chronology this should be reasonably set in the of 9th century BCE with extensions into the early 8th century BCE. So far, no prominent Iron Age I occupation with related materials has been clearly identified at the site. After the massive Middle Bronze Age II destruction only few traces and scarce materials belonging to the second half of the second millennium BCE were found.<sup>84</sup> Therefore the very first appearance of Red Slip Ware at Zincirli and its role in setting the IA I – IA II transition need to be clarified with more investigations and more data. We must therefore rely on the documentation of nearby sites, especially in the Amuq, which provides an uninterrupted occupation sequence from the Late Bronze to the late Iron Age. Following this data, it seems clear that Red Slip is not introduced as a foreign element, but it follows the development of Bronze and early Iron local assemblages.<sup>85</sup> Shallow bowls with red banded decoration were already attested in Late Bronze Age in the Amuq, in Cilicia and in Northern Syria and the procedure of slipping and burnishing appears as a revival and an evolution of this trend, becoming dominant in the Iron Age II and continuing with different spots in Iron Age III.<sup>86</sup>

In the following Iron Age III period (i.e. second half of 8th century and 7th century BCE, historically coincident with the inclusion within the Neo-Assyrian empire) the overall ceramics horizon is characterized by a strong continuity in morphological repertoire and technological features (fabrics, temper and firing), with an

80 Matthäus 1985, pp. 134-135, Taf. 25; see the case of Tell Afis deep bowls in Soldi 2013, pp. 211-213.

81 The role of painted and slipped ceramics in official feasts has been discussed recently, among other cases, from the perspective of the west chambers in Area T at Tel Dan in Northern Israel (Greer 2013, pp. 94-96, see especially note 116 with bibliography), and in the funerary context of the Phoenician cemetery of Tyre al-Bass (Núñez 2017, with bibliography).

82 Winter 1988, pp. 198-200; von Luschan – Andrae 1943, pp. 117-119, Taf. 56-57.

83 Struble – Herrmann 2009, p. 23, fig. 5.

84 A small lot of materials belonging to the Late Bronze Age II (14th-13th century BCE) was identified above the MB II in Area 2 in the 2021 excavation season.

85 Pucci 2020, pp. 23-24.

86 Pucci – Soldi 2019, pp. 354-355.

evident decrease in surface treatments and use of painted decorations. Red Slip Ware in particular is still attested at the site, but it does not seem to play anymore any specific role in the local inventory. We may tentatively explain this issue with a possible change in the habits of communal consumptions of food and drinking, probably connected to Assyrianized habits or simply the adoption of new sets of vessels as a new fashion coming along with the Assyrian conquerors and influencing the local stakeholders. This should be confirmed by the major impact of carinated bowls and bowls with thickened folded rims, as typical of Assyrian ware inventories, the appearance of some exemplars of Assyrian eggshell Palace Ware and glazed ceramics, exemplars of so-called Assyrian bottles and finally the statistical increase of common simple ware potstands, a marker which is connected to a larger employment of pointed or rounded-bottom vessels, as it is typical in Assyrian milieus.<sup>87</sup>

This consideration leads us to interpret the evolution of local pottery inventories as a smooth shifting from being part of the same group of north-west Syria's assemblages, especially similar to the sites of the Amuq, in the Iron Age II, to a major resemblance with Karkemish and the Euphrates area in the Iron Age III. This does not imply any rigid belonging to regional borders, but it is the indication of a new sphere of influence coming from the east within the framework of a general horizon of material culture which remains strongly homogenous.

It is therefore clear that, while sharing some common features crossing physical and cultural borders, the development and diffusion of Red Slip Ware is better understood throughout a regional perspective, taking into account the local variations from site to site in a diachronic perspective.<sup>88</sup> It is hard to identify a unique paradigm in the revival and abandonment trends of specific classes of materials which were affected by different political as well as socio-economic elements. In order to understand clearly the phenomenon, we have to rely on micro-regional evaluation and intra-site contextual analysis because not every community's settlement is a receptor of the same issues at the same turn of time. We are now establishing a sound set of data for the İslahiye plain, where Zincirli can be understood together with the Iron Age settlement of Taşlı Geçit Höyük, and thus be compared in a wider perspective with the Amuq and north-western Syrian sites, the area of the Euphrates under the influence of Karkemish and of Assyria, and the Cilician plains open to Cyprus and to the Mediterranean.

In this respect, Zincirli's documentation provides some new further elements that highlight the evolution of the Aramaean kingdom of Sam'al as one of the key-role players on the cultural and geographic borders between southern Anatolia and Northern Syria.

#### REFERENCES

- Besana – Da Ros – Iamoni 2008 = R. Besana – M. Da Ros – M. Iamoni, *Excavations on the Acropolis of Mishrifeh, Operation J. A New Early Bronze Age III – Iron Age III Sequence for Central Inner Syria. Part 2*, in «Akkadica» 129, 2008, pp. 129-180.
- Blaylock 2016 = S.R. Blaylock, *Tille Höyük 3. The Iron Age. 2. Pottery, Objects and Conclusions*, London 2016 («British Institute at Ankara Monograph», 50).
- Bonomo – Zaina 2014 = A. Bonomo – F. Zaina, *The Iron Age II-III Pottery Assemblage from Karkemish and Yunus*, in N. Marchetti (ed.), *Karkemish. An Ancient Capital on the Euphrates*, Bologna 2014 («OrientLab», 2), pp. 137-144.
- Braemer 1986 = F. Braemer, *La céramique à engobe rouge de l'Âge du Fer à Bassit*, in «Syria» 63, 1986, pp. 221-246.
- Bunnens 2000 = G. Bunnens (ed.), *Essays on Syria in the Iron Age*, Louvain-Paris-Sterling (Virginia) 2000 («AncNear-EastSt. Suppl.», 7).

87 These elements were already pointed out in Soldi 2019, pp. 174, 177-180; see also Soldi 2020.

88 Pucci – Soldi 2019.

- Cecchini 1998 = S.M. Cecchini, *Area G. The Iron I-III Levels. Architecture, Pottery and Finds*, in S.M. Cecchini – S. Mazzoni (edd.), *Tell Afis (Siria). Scavi sull'acropoli 1988-1992. The 1988-1992 Excavations on the Acropolis*, Pisa 1998 («Ricerche di Archeologia del Vicino Oriente», 1), pp. 273-365.
- Cecchini 2000 = S.M. Cecchini, *Un bâtiment mystérieux sur l'acropole de Tell Afis*, in P. Matthiae – A. Enea – L. Peyronel – F. Pinnock (edd.), *Proceedings of the First International Congress on the Archaeology of the Ancient Near East* (Rome, 18th-23rd May 1998), Roma 2000, pp. 199-212.
- Cooper 2006 = L. Cooper, *The Pottery from Tell Acharneh. Part I: Typological Considerations and Dating According to Excavated Areas in the Upper and Lower Towns, 1998-2002*, in M. Fortin (ed.), *Tell Acharneh 1998-2004. Rapports préliminaires sur les campagnes de fouilles et saison d'études. Preliminary Reports on Excavation Campaigns and Study Season*, Turnhout 2006 («Subartu», 18), pp. 140-190.
- D'Agata 2019 = A.L. D'Agata, *Misis (Ancient Mopsouestia) and the Plain of Cilicia in the Early First Millennium BC: Material Entanglements, Cultural Boundaries, and Local Identities*, in «SMEA» 5, 2019, pp. 87-110.
- Dornemann 2000 = R.H. Dornemann, *The Iron Age Remains at Tell Qarqur in the Orontes Valley*, in Bunnens 2000, pp. 459-485.
- Du Mesnil du Buisson 1932 = R. Du Mesnil du Buisson, *Une campagne de fouilles à Khan Sheikhoun*, in «Syria» 13, 1932, pp. 171-188.
- Du Plat Taylor – Seton Williams – Waechter 1950 = J. Du Plat Taylor – M.V. Seton Williams – J. Waechter, *The Excavations at Sakce Gözü*, in «Iraq» 12, 1950, pp. 53-138.
- Falcone – Lazzarini 1998 = R. Falcone – L. Lazzarini, *IV.4 - Analisi minero-petrografiche e chimiche su campioni di ceramica*, in S.M. Cecchini – S. Mazzoni (edd.), *Tell Afis (Siria). Scavi sull'acropoli 1988-1992. The 1988-1992 Excavations on the Acropolis*, Pisa 1998 («Ricerche di Archeologia del Vicino Oriente», 1), pp. 481-500.
- Fiorentino 2006 = R. Fiorentino, *Le campagne 1978, 1981 e 1986. La ceramica*, in F. Baffi (ed.), *Tell Tuqan. Ricerche archeologiche italiane nella regione del Maath (Siria)*, Galatina (Lecce) 2006, pp. 51-111.
- Fiorentino 2014 = R. Fiorentino, *The Urban Settlement at Tell Tuqan during the Iron Age*, in F. Baffi – R. Fiorentino – L. Peyronel (edd.), *Tell Tuqan Excavations and Regional Perspectives. Cultural Developments in Inner Syria from the Early Bronze Age to the Persian/Hellenistic Period*, Lecce 2014, pp. 391-426.
- Fugmann 1958 = E. Fugmann, *L'architecture des périodes pré-hellénistiques. Hama. Fouilles et recherches de la Fondation Carlsberg 1931-1938. II.1*, København 1958 («Nationalmuseets skrifter. Større beretninger», 4).
- Greer 2013 = J.S. Greer, *Dinner at Dan. Biblical and Archaeological Evidence for Sacred Feasts at Iron Age II Tel Dan and Their Significance*, Leiden-Boston 2013 («Culture and History of the Ancient Near East», 66).
- Herrmann 2017a = V.R. Herrmann, *Appropriation and Emulation in the Earliest Sculptures from Zincirli (Iron Age Sam'al)*, in «AJA» 121, 2017, pp. 237-274.
- Herrmann 2017b = V.R. Herrmann, *Urban Organization under Empire: Iron Age Sam'al (Zincirli, Turkey) from Royal to Provincial Capital*, in «Levant» 49, 2017, pp. 284-311.
- Herrmann – Schloen 2018 = V.R. Herrmann – D.J. Schloen, *Zincirli Höyük, Ancient Sam'al: A Preliminary Report on the 2015 Excavation Season*, in B. Horejs – C. Schwall – V. Müller – M. Luciani – M. Ritter – M. Guidetti – R.B. Salisbury – F. Höflmayer – T. Bürge (edd.), *Proceedings of the 10th International Congress on the Archaeology of the Ancient Near East* (Vienna, 25-29 April 2016), vol. 2, Wiesbaden 2018, pp. 521-534.
- Herrmann – Schloen 2021 = V.R. Herrmann – D.J. Schloen, *Middle Bronze Age Zincirli: The Date of "Hilani I" and the End of Middle Bronze II*, in «BASOR» 385, 2021, pp. 33-51. DOI: 10.1086/711911
- Iwasaki et al. 2009 = T. Iwasaki – K. Wakita – S. Ishida – H. Wada, *Tell Mastuma. An Iron Age Settlement in Northwest Syria*, Tokyo 2009.
- Jamieson 1999 = A.S. Jamieson, *Neo-Assyrian Pottery from Tell Abmar*, in A. Hausleiter – A. Reiche (edd.), *Iron Age Pottery in Northern Mesopotamia, Northern Syria and South-Eastern Anatolia*, Münster 1999 («Alttertumskunde des vorderen Orients», 10), pp. 287-308.
- Jamieson 2000 = A.S. Jamieson, *Identifying Room Use and Vessel Function. A Case-Study of Iron Age Pottery from Building C2 at Tell Abmar, North Syria*, in Bunnens 2000, pp. 259-303.
- Karacic – Osborne 2016 = S. Karacic – J. Osborne, *Eastern Mediterranean Economic Exchange during the Iron Age: Portable X-Ray Fluorescence and Neutron Activation Analysis of Cypriot-Style Pottery in the Amuq Valley, Turkey*, in «PLOS ONE» 11, 2016, pp. 1-17. DOI: 10.1371/journal.pone.0166399



- Karageorghis 2000 = V. Karageorghis, *Ancient Art from Cyprus. The Cesnola Collection in the Metropolitan Museum of Art*, New York 2000.
- Kulemann-Ossen – Mönninghoff 2019 = S. Kulemann-Ossen – H. Mönninghoff, *Hybridity of Styles: Iron Age Pottery from Sirkeli Höyük*, in «SMEA» 5, 2019, pp. 111-146.
- Lebeau 1983 = M. Lebeau, *La céramique de l'Âge du Fer II-III à Tell Abou Danné et ses rapports avec la céramique contemporaine en Syrie*, Paris 1983 («Recherche sur les civilisations. Cahier», 12).
- Lehmann 1996 = G. Lehmann, *Untersuchungen zur späten Eisenzeit in Syrien und Libanon: Stratigraphie und Keramikformen zwischen ca. 720 bis 300 v. Chr.*, Münster 1996 («Altertumskunde des Vorderen Orients», 5).
- Lehmann 1998 = G. Lehmann, *Trends in the Local Pottery Development of the Late Iron Age and Persian Period in Syria and Lebanon, ca. 700 to 300 B.C.*, in «BASOR» 311, 1998, pp. 7-37.
- Lehmann 2008 = G. Lehmann, *North Syria and Cilicia, c. 1200 – 330 BCE*, in C. Sagona (ed.), *Beyond the Homeland: Markers in Phoenician Chronology*, Leuven-Paris-Dudley (MA) 2008 («AncNearEastSt Suppl.», 28), pp. 205-246.
- Lehmann 2015 = G. Lehmann, *Iron Age IIA–B: Northern Coastal Plain*, in S. Gitin (ed.), *The Ancient Pottery of Israel and Its Neighbors from the Iron Age through the Hellenistic Period*, 2 vols., Jerusalem 2015, pp. 115-134.
- Lehmann 2016 = G. Lehmann, *The Archaeology of the Assyrian Period in Cilicia in the Light of the Kinet Höyük Excavations*, in J. MacGinnis – D. Wicke – T.L. Greenfield (edd.), *The Provincial Archaeology of the Assyrian Empire*, Cambridge 2016, pp. 321-333.
- Luciani 2005 = M. Luciani, *Area G. The Iron Age Productive Area (Period IX) and the Inhumation Cemetery (Period X)*, in L. Bachelot – F.M. Fales (edd.), *Tell Shiukh Fawqani, 1994-1998*, 2 vols., Padova 2005 («History of the Ancient Near East. Monographs», 6.2), pp. 720-925.
- von Luschan – Andrae 1943 = F. von Luschan – W. Andrae, *Ausgrabungen in Sendschirli V: Die Kleinfunde von Sendschirli*, Berlin 1943 («Mitteilungen aus den Orientalischen Sammlungen», 15).
- Makinson 2005 = M. Makinson, *Le Chantier F. Archéologie. La stratigraphie générale et l'occupation de l'Âge du Fer*, in L. Bachelot – F.M. Fales (edd.), *Tell Shiukh Fawqani, 1994-1998*, 2 vols., Padova 2005 («History of the Ancient Near East. Monographs», 6.1), pp. 411-580.
- Manuelli – Pittman 2018 = F. Manuelli – H. Pittman, *A "Flame and Frond" Ivory Plaque from the Neo-Hittite Excavations at Arslantepe/Melid. Regionalism and Communities in Iron Age Anatolia*, in «Origini» 41, 2018, pp. 139-169.
- Marchetti 2011 = N. Marchetti, *The 2009 Joint Turkish-Italian Excavations at Taşlı Geçit Höyük*, in «Kazı Sonuçları Toplantısı» 32, 2011, pp. 297-310.
- Marchetti 2012 = N. Marchetti, *The 2010 Joint Turkish-Italian Excavations at Taşlı Geçit Höyük*, in «Kazi Sonuçları Toplantısı» 33, 2012, pp. 531-546.
- Marchetti 2014 = N. Marchetti (ed.), *Karkemish. An Ancient Capital on the Euphrates*, Bologna 2014 («OrientLab», 2).
- Matthäus 1985 = H. Matthäus, *Metallgefäße und Gefäßuntersätze der Bronzezeit, der geometrischen und archaischen Periode auf Cypern: Mit einem Anhang der bronzezeitlichen Schwertfunde auf Cypern*, München 1985 («Prähistorische Bronzefunde», 2.8).
- Mazzoni 1992 = S. Mazzoni, *L'Età del Ferro a Tell Mardikh e nella sua regione*, in S. Mazzoni (ed.), *Tell Afis e l'Età del Ferro*, Pisa 1992, pp. 99-155.
- Mazzoni 2000 = S. Mazzoni, *Syria and the Periodization of the Iron Age: A Cross-Cultural Perspective*, in Bunnens 2000, pp. 31-60.
- Mazzoni 2014 = S. Mazzoni, *The Archaeology of Tell Afis and the Iron Age II-III in Syria: A Reassessment*, in F. Baffi – R. Fiorentino – L. Peyronel (edd.), *Tell Tuqan Excavations and Regional Perspectives. Cultural Developments in Inner Syria from the Early Bronze Age to the Persian/Hellenistic Period*, Lecce 2014, pp. 343-390.
- Morandi Bonacossi 2009 = D. Morandi Bonacossi, *Continuity and Change in the Town Planning and Material Culture of Iron Age II and III Mishrifeh, Central Syria*, in «Syria» 86, 2009, pp. 119-132.
- Morgan – Soldi 2021 = K.R. Morgan – S. Soldi, *Middle Bronze Age Zincirli: An Interim Report on Architecture, Small Finds, and Ceramics from a Monumental Complex of the 17th Century B.C.E.*, in «BASOR» 385, 2021, pp. 53-86. DOI: 10.1086/711910
- Novák et al. 2017 = M. Novák – A.L. D'Agata – I. Caneva – C. Eslick – C. Gates – M.-H. Gates – K.S. Girginer – Ö. Oyman-Girginer – É. Jean – G. Köroğlu – E. Kozal – S. Kulemann-Ossen – G. Lehmann – A. Özyar – T. Ozaydin – J.N. Postgate – F. Şahin – E. Ünlü – R. Yağcı – D. Yaşin-Meier, *A Comparative Stratigraphy of Cilicia:*

- Results of the first three Cilician Chronology Workshops*, in «AoF» 44, 2017, pp. 150-186. <https://doi.org/10.1515/afo-2017-0013>
- Núñez 2017 = F.J. Núñez, *The Tyrian Cemetery of al-Bass and the Role of Ceramics in the Phoenician Funerary Ritual*, in «Levant» 49, 2017, pp. 174-191. DOI: 10.1080/00758914.2017.1391026
- Oggiano 1997 = I. Oggiano, *The Pottery of Iron Age II from Tell Afis*, in «Contributi della Scuola di Specializzazione in Archeologia dell'Università degli Studi di Pisa» 1, 1997, pp. 187-213.
- O'Hara 2012 = D. O'Hara, *Skeuomorphology and Quotation*, in «Morphomata» 2, 2012, pp. 281-294.
- Orthmann 1971 = W. Orthmann. *Untersuchungen zur späthethitischen Kunst*, Bonn 1971 («Saarbrücker Beiträge zur Altertumskunde», 8).
- Osborne 2013 = J.F. Osborne, *Sovereignty and Territoriality in the City-State: A Case Study from the Amuq Valley, Turkey*, in «Journal of Anthropological Archaeology» 32, 2013, pp. 774-790.
- Osborne 2021 = J.F. Osborne, *The Syro-Anatolian City-States: An Iron Age Culture*, New York 2021.
- Osborne et al. 2019 = J.F. Osborne – T.P. Harrison – S. Batiuk – L. Welton – J.P. Dessel – E. Denel – Ö. Demirci, *Urban Built Environments in Early 1st Millennium B.C.E. Syro-Anatolia: Results of the Tayinat Archaeological Project, 2004–2016*, in «BASOR» 382, 2019, pp. 261-312. DOI: 10.1086/705728
- Pizzimenti 2014-2015 = S. Pizzimenti, *The Iron Age II-III Pottery Sequence at Tell Mardikh-Ebla within the Framework of the Iron Age Inner Syria. Remarks from a Work in Progress*, in P. Matthiae – M. Abdulkarim – F. Pinnock – M. Alkhalid (edd.), *Studies on the Archaeology of Ebla after 50 Years of Discoveries*, in «AAS» 57-58, 2014-2015, pp. 235-244.
- Pizzimenti – Zaina 2016 = S. Pizzimenti – F. Zaina, *The Iron Age at Karkemish between Tradition and Innovation. The Case Study of the Pottery Assemblage from Area C*, in R.A. Stucky – O. Kaelin – H.-P. Mathys (edd.), *Proceedings of the 9th International Congress on the Archaeology of the Ancient Near East* (Basel, 9-13 June 2014), vol. 3, Wiesbaden 2016, pp. 361-376.
- Pucci 2019 = M. Pucci, *Excavations in the Plain of Antioch, Volume 3. Stratigraphy and Materials from Chatal Höyük*, 2 vols., Chicago 2019 («OIP», 143).
- Pucci 2020 = M. Pucci, *Traded Goods in the Amuq during the Iron Age: Cypriot, Phoenician and Aegyptian Artefacts at Chatal Höyük*, in «RStFen» 48, 2020, pp. 7-34.
- Pucci – Soldi 2019 = M. Pucci – S. Soldi, *Going Red in the Iron Age II: The Emergence of Red-Slipped Pottery in Northern Levant and Inner Syria*, in S. Valentini – G. Guarducci (edd.), *Between Syria and the Highlands. Studies in Honor of Giorgio Buccellati and Marilyn Kelly-Buccellati*, Roma 2019 («SANEM – Studies on the Ancient Near East and the Mediterranean», 3), pp. 352-364.
- Riis 1990 = J.P. Riis, *Hama. Fouilles et Recherches de la Fondation Carlsberg, 1931-1938. Les objets de la période dite syro-hittite (Âge du Fer)*, København 1990 («Nationalmuseets skrifter. Større beretninger», 12).
- Rossi 2011 = M. Rossi (ed.), *Archaeology of Cooperation Afis – Deinit and the Museum of Idlib. Activities in the Frame of the MEDA Project*, Napoli 2011.
- Russo 2018 = G. Russo, *The Iron Age Pottery from Tell Mishrifeh (Qatna): Preliminary Results from the German-Syrian Excavations*, in B. Horejes (ed.), *Proceedings of the 10th International Congress on the Archaeology of the Ancient Near East* (Vienna, 25-29 April 2016), vol. 2, Wiesbaden 2018, pp. 601-612.
- Schloen 2014 = D.J. Schloen, *The City of Katumuwa: The Iron Age Kingdom of Sam'al and the Excavation of Zincirli*, in V.R. Herrmann – D.J. Schloen (edd.), *In Remembrance of Me: Feasting with the Dead in the Ancient Middle East*, Chicago 2014 («OIP», 37), pp. 27-38.
- Schloen – Fink 2009 = D.J. Schloen – A.S. Fink, *New Excavations at Zincirli Höyük in Turkey (Ancient Sam'al) and the Discovery of an Inscribed Mortuary Stele*, in «BASOR» 356, 2009, pp. 1-13.
- Soldi 2009 = S. Soldi, *Aramaean and Assyrians in North-Western Syria: Material Evidence from Tell Afis*, in «Syria» 86, 2009, pp. 97-118.
- Soldi 2013 = S. Soldi, *Red Slip Ware from the Acropolis of Tell Afis: The Evidence of Area G*, in S. Mazzone – S. Soldi (edd.), *Syrian Archaeology in Perspective: Celebrating 20 Years of Excavations at Tell Afis. Proceedings of the International Meeting: "Percorsi di Archeologia Siriana: Giornate di studio"* (Pisa, 27-28 novembre 2006), Pisa 2013 («Ricerche di Archeologia del Vicino Oriente», 4), pp. 199-217.
- Soldi 2019 = S. Soldi, *The Iron Age Pottery of Zincirli Höyük: An Assemblage among Neighbouring Traditions*, in «SMEA» 5, 2019, pp. 165-184.

- Soldi 2020 = S. Soldi, *The Northern Levant and Assyria: Ceramic Productions in the Kingdom of Sam'al during the Neo Assyrian Expansion to the West*, in K. Gavagnin – R. Palermo (edd.), *Imperial Connections. Interactions and Expansion from Assyria to the Roman Period. Proceedings of the 5th "Broadening Horizon" Conference* (Udine, 5-8 June 2017), vol. 2, Trieste 2020 («West & East Monografie», 3), pp. 165-182.
- Stern 2015 = E. Stern, *Iron Age I–II Phoenician Pottery*, in S. Gitin (ed.), *The Ancient Pottery of Israel and Its Neighbors from the Iron Age through the Hellenistic Period*, 2 vols., Jerusalem 2015, pp. 435-482.
- Stronach 1995 = D. Stronach, *The Imagery of the Wine Bowl: Wine in Assyria in the Early First Millennium*, in P.E. McGovern – S.J. Fleming – S.H. Katz (edd.), *The Origins and Ancient History of Wine*, Amsterdam 1995, pp. 175-195.
- Struble – Herrmann 2009 = E.J. Struble – V.R. Herrmann, *An Eternal Feast at Sam'al: The New Iron Age Mortuary Stele from Zincirli in Context*, in «BASOR» 356, 2009, pp. 15-49.
- Venturi 2007 = F. Venturi, *La Siria nell'età delle trasformazioni (XIII-X sec. a.C.). Nuovi contributi dallo scavo di Tell Afis*, Bologna 2007 («Studi e Testi Orientali», 8; «Serie Archeologica», 1).
- Venturi 2020 = F. Venturi, *Tell Afis. The Excavations of Areas E2-E4 Phases V-I. The End of the Late Bronze / Iron Age I Sequence. Stratigraphy, Pottery and Small Finds*, 2 vols., Firenze 2020 («Studi di Archeologia Siriana», 4).
- Wada 1994 = H. Wada, *Pottery Vessels in the Iron Age II in the South Area of Tell Mastuma in 1993 Season*, in «BAnCOrMus» 15, 1994, pp. 51-76.
- Wakita et al. 1994 = S. Wakita – I. Asano – H. Wada – A. Tsuneki – T. Nakamura, *Tell Mastuma. A Preliminary Report of the Excavations in Idlib, Syria, 1993*, in «BAnCOrMus» 15, 1994, pp. 23-49.
- Wakita – Wada – Nishiyama 2000 = S. Wakita – H. Wada – S. Nishiyama, *Tell Mastuma. Change in Settlement Plans and Historical Context during the First Quarter of the First Millennium B.C.*, in Bunnens 2000, pp. 537-557.
- Wartke 2005 = R.-B. Wartke, *Sam'al: ein aramäischer Stadtstaat des 10. Bis 8. Jhs. v. Chr. und die Geschichte seiner Erforschung*, Berlin 2005.
- Whincop 2007 = M.R. Whincop, *The Iron Age II at Tell Nebi Mend: Towards an Explanation of Ceramics Regions*, in «Levant» 39, 2007, pp. 185-212.
- Whincop 2009 = M.R. Whincop, *Pots, People, and Politics: A Reconsideration of the Role of Ceramics in Reconstructions of the Iron Age Northern Levant*, Oxford 2009 («BAR International Series», 1902).
- Winter 1988 = I. Winter, *North Syria as a Bronzeworking Centre in the Early First Millennium BC*, in J. Curtis (ed.), *Luxury Commodities at Home and Abroad: Bronzeworking Centres of Western Asia c. 1000-539 B.C.*, London 1988, pp. 193-225.
- Zaina 2013 = F. Zaina, *A Functional and Morphological Analysis of the Iron Age Pottery Assemblage from Taşlı Geçit Höyük, Turkey*, in L. Bombardieri – A. D'Agostino – G. Guarducci – V. Orsi – S. Valentini (edd.), *SOMA 2012. Identity and Connectivity. Proceedings of the 16th Symposium on Mediterranean Archaeology* (Florence, 1-3 March 2012), Oxford 2013 («BAR International Series», 2581), pp. 65-74.
- Zaina 2019 = F. Zaina, *The Iron Age*, in F. Zaina (ed.), *Excavations at Karkemish I. The Stratigraphic Sequence of Area G in the Inner Town*, Bologna 2019 («OrientLab Series Maior», 3), pp. 116-249.